

在使用缝纫机之前请阅读本使用说明书。
请将本使用说明书放在便于查阅的地方保管。



自动直驱高速平缝机 A7200系列
Automatic high speed lockstitch sewing machine

使用说明书
OPERATION MANUAL
零件手册
PARTS BOOK



手机官网



官方订阅号

浙江中捷缝纫科技有限公司
ZOJE SEWING MACHINE CO.,LTD

为了创造更加美好的环境

请您协作

首先对您使用本公司的产品表示衷心的感谢！

本公司致力于关爱地球环境，制定了“智能制造、绿色制造”的基本方针。当地的公民在环境保护活动中也应该对当地社会、环境二方面尽每个人的微薄之力。

因此，希望您能配合这个计划，作为环境保护活动的一环，在平时处理废弃物的时候能多加注意。

1. 不用的包装材料，为了能再次回收利用，请交付给当地相关回收公司进行处理。
2. 使用完的润滑油、请根据相关的法律和规定进行妥善处理。
3. 产品保养或修理需要更换零部件时，有不需要的电路板和电子零件，以及产品废弃时，请作为电子废弃物处理。

In order to create a better environment

Please cooperate with you

First of all, I would like to express my heartfelt thanks to you for using our products.

Our company is committed to caring for the earth's environment and has formulated the basic policy of "intelligent manufacturing and green manufacturing". Local citizens in environmental protection activities should also do little to the local community, the environment two aspects of everyone's contribution.

Therefore, I hope you can cooperate with this plan, as part of the environmental protection activities, when dealing with wastes in peacetime can pay more attention.

1. Unused packaging materials, in order to be recycled again, please send them to the local recycling company for disposal.
2. Lubricants used shall be properly handled according to relevant laws and regulations.
3. When parts need to be replaced in product maintenance or repair, there are unnecessary circuit boards and electronic parts, and when products are discarded, please treat them as electronic waste.

非常感谢您购买本公司的工业缝纫机

在使用缝纫机之前，请仔细阅读<为了您的安全使用>和使用说明。

工业缝纫机的特性之一，因为要在机针和旋梭等运动零部件附近进行操作，而这些零部件很容易引起受伤的危险，所以请在受过培训的人或熟练人员的安全操作知识的指导下，正确地使用本缝纫机。



为了您的安全使用

[1] 安全使用的标记及其意义

本使用说明书及产品所使用的标记和图案记号是为了您的安全而正确地使用产品，防止您及其他人受到危害和损害。

表示方法及含意如下。

标记

 危险	该内容表示如果忽视此标记而进行了错误的操作，必将导致死亡或重伤。
 警告	该内容表示如果忽视此标记而进行了错误的操作，肯定会引起人员死亡或重伤。
 注意	如果忽视此标记而进行错误的操作，有可能会引起人员受到轻微或中度的伤害。

图案和符号



..... 该符号(△)表示“应注意事项”。
三角中的图案表示必须要注意的实质内容。
(例如，左边的图案表示“当心受伤”。)



..... 该符号(⊘)表示“禁止”。



..... 该符号(●)表示“必须”。
圆圈中的图案表示必须要做的事情的实质内容。
(例如，左边的图案表示“必须接地”。)

Thank you very much for purchasing our industrial sewing machine
Before using the sewing machine, please read <for your safe use> and use instructions carefully

The characteristic of industrial sewing machine is that it should be operated near the moving parts such as needles and spindles, which are easy to cause injury, so please use the sewing machine correctly under the guidance of the safety operation knowledge of trained or skilled personnel.



For Your Safe Use

[1] Security Usage Markup And Its Significance

The labels and pattern marks used in this instructions and products are for your safety and correct use of the products to prevent you and others from being harmed and damaged.

The methods and implications are as follows.

Sign

 Danger	This content indicates that if this mark is mishandled, it will cause death to become serious.
 Warning	This content indicates that if this mark is mishandled, people will die or be seriously injured.
 Note	That if this mark is mishandled, it may cause minor or moderate injuries.

Patterns And Symbols



..... The symbol (\triangle) indicates "points for attention".
The pattern in the triangle represents the essential content that must be paid attention to.
(For example, the pattern on the left shows "watch out for injuries".)



..... The symbol (\otimes) indicates "prohibition".



..... The symbol (\bullet) indicates "must".
The pattern in the circle indicates the substance of what must be done.
(For example, the pattern on the left shows "must be grounded".)

[2] 安全注意事项

⚠ 危险



在关闭电源开关并将电源插头从插座上拔下后,至少等待5分钟,再打开控制箱盖。触摸带有高电压的区域将会造成人员伤亡。

⚠ 警告



缝纫机内不允许进入任何液体,否则会引起火灾、电击或操作故障。

如果缝纫机内(机头或控制箱)进入任何液体,请立即关闭电源,并将电源插头从插座上拔出,然后联系销售商或资深技术人员。

⚠ 注意

使用环境



请不要在有电源线干扰及静电干扰等有强电气干扰源影响的环境下使用。
强电气干扰源可能会影响缝纫机的正确操作。



电源电压的波动应该在额定电压的±10%以内的环境下使用。
电压大幅度的波动会影响缝纫机的正确操作。



电源容量应大于缝纫机的消耗电量。电源容量不足会影响缝纫机的正确操作。



环境温度应在5°C-35°C 的范围内使用。
低温或高温会影响缝纫机的正确操作。



相对湿度应在45%-85%的范围内,并且设备内不会形成结露的环境下使用。干燥或多湿的环境和结露会影响缝纫机的正确操作。



万一发生雷电暴风雨时,关闭电源开关,并将电源插头从插座上拔下。雷电可能会影响缝纫机的正确操作。



请勿将USB存储器以外的设备连接到USB连接端口上。否则有可能导致故障。

安 装



请让受过培训的技术人员来安装缝纫机。



请委托购买商店或电气专业人员进行电气配线。



缝纫机重约3kg,安装工作必须由两人以上来完成。



在安装完成前,请不要连接电源,如果误踩下脚踏板时,缝纫机动作会导致受伤。



请在切断电源后,再拔掉电插头。
不然易成为控制箱发生故障的原因。



必须接地。
接驳地线不牢固,是造成触电或误动作的原因。



固定电缆时,不要过度弯曲电缆或用卡钉固定得过紧,会引起火灾或触电的危险。



如果使用带小脚轮的工作台,则应该固定小脚轮,使其不能移动。



缝纫机头倒下时,请一定要固定工作台,不可使其随意移动。
工作台移动易发生脚等被夹住之事故,是导致人身事故的原因。



缝纫机头倒下或竖起时,请用双手进行操作。
单手操作时因缝纫机的重量万一滑落易导致受伤。



使用润滑油和黄油时,务必戴好保护眼镜和保护手套等,以防润滑油落入眼中或沾在皮肤上,这是引起发炎的原因。
另外,润滑油或黄油不能饮用,否则会引起呕吐和腹泻。
将油放在小孩拿不到的地方。

[2] Safety Precautions

Danger



After closing the power switch and unplugging the power plug from the socket, wait for at least 5 minutes before opening the control box cover. Touching areas with high voltage can cause casualties.

Warning



No liquid is allowed to enter the sewing machine, otherwise it will cause fire, electric shock and operation failure.



If any liquid enters the sewing machine (head or control box), turn off the power supply immediately, pull the plug out of the socket, and contact the vendor or senior technicians.

Be Careful

Use Environment



Please don't use in the environment with strong electrical interference sources such as power line interference and electrostatic interference.

Strong electrical interference sources may affect the correct operation of sewing machines.



The fluctuation of power supply voltage should be used in the environment of rated voltage less than $\pm 10\%$.

The large fluctuation of voltage will affect the correct operation of sewing machine.



The power supply capacity should be greater than the power consumption of the sewing machine. Insufficient power supply capacity will affect the correct operation of sewing machine.



The ambient temperature should be used in the range of 5-35 degrees Celsius.

Low or high temperature will affect the correct operation of sewing machine.



Relative humidity should be in the range of 45% - 85%, and the equipment will not form condensation environment. Dry or wet environment and dew will affect the correct operation of sewing machine.



In case of thunderstorm, turn off the power switch and pull the power plug off the socket. Lightning may affect the correct operation of sewing machine.



Do not connect devices other than USB memory to USB connection ports. Otherwise, it may lead to failure.

Install



Ask trained technicians to install sewing machines.



Please commission the purchase shop or electrical professionals for electrical wiring.



The sewing machine weighs about 36Kg. Installation must be completed by more than two people.



Please do not connect the power supply before the installation is completed. If you step on the pedal by mistake, the sewing machine will cause injury.



Please unplug the plug after cutting off the power supply. Otherwise, it will easily become the cause of the failure of the control box.



It must be grounded.

Insufficient ground connection is the cause of electric shock or misoperation.



When fixing the cable, do not bend the cable excessively or fix it too tightly with clamps, which may cause fire or electric shock.



If a worktable with casters is used, the casters should be fixed so that they cannot move.



When the head of the sewing machine falls down, please make sure that the worktable is fixed and not moved at will. Accidents such as foot clamping have occurred in the movement of worktable, which is the cause of personal accidents.



When the sewing machine head falls down or stands up, please operate with both hands.

One-handed operation can easily cause injury if the weight of the sewing machine slips.



When lubricating oil and butter are used, it is necessary to wear protective glasses and gloves to prevent lubricating oil from falling into serious or sticking to the skin, which is the cause of inflammation.

In addition, lubricants or butter should not be drunk, otherwise vomiting and diarrhea will occur.

Keep oil out of reach of children

⚠️ 注意

缝 纫



本缝纫机仅限于接受过安全操作培训的人员使用。



本缝纫机不能用于除缝纫外的任何其他用途。



使用缝纫机时必须戴上保护眼镜。

如果不戴保护眼镜，断针时就会有危险，机针的折断部分可能会弹入眼睛并造成伤害。



发生下列情况时，请切断电源。

否则误踩下脚踏板时，缝纫机动作会导致受伤。

- 机针穿线时
- 更换机针或梭芯时
- 缝纫机不使用，或人离开缝纫机时



如果使用带小脚轮的工作台，则应该固定小脚轮，使其不能移动。



为了安全起见，在使用本缝纫机之前，请安装保护装置。如果未安装这些安全装置就使用缝纫机，会造成人身伤害及缝纫机损坏。



缝纫过程中，不要触摸任何运动部件或将物件靠在运动部件上，因为这会导致人员受伤或缝纫机损坏。



缝纫机头倒下时，请一定要固定工作台，不可使其随意移动。

工作台移动易发生脚等被夹住之事故，是导致人身事故的原因。



缝纫机头倒下或竖起时，请用双手进行操作。

单手操作时因缝纫机的重量万一滑落易导致受伤。



如果缝纫机操作中发生误动作，或听到异常的噪音或闻到异常的气味，应立即切断电源。然后请与购买商店或受过培训的技术人员联系。



如果缝纫机出现故障，请与购买商店或受过培训的技术人员联系。

清 洁



在开始清洁作业前，请切断电源。

如果误踩下脚踏板时，缝纫机动作会导致人员受伤。



缝纫机头倒下时，请一定要固定工作台，不可使其随意移动。

工作台移动易发生脚等被夹住之事故，是导致人身事故的原因。



缝纫机头倒下或竖起时，请用双手进行操作。

单手操作时因缝纫机的重量万一滑落易导致受伤。



使用润滑油和黄油时，务必戴好保护眼镜和保护手套等，以防润滑油落入眼中或沾在皮肤上，这是引起发炎的原因。

另外，润滑油或黄油不能饮用，否则会引起呕吐和腹泻。

将油放在小孩拿不到的地方。

保 养 和 检 查



只有经过训练的技术人员才能进行缝纫机的维修、保养和检查。



与电气有关的维修、保养和检查请委托购买商店或电气专业人员进行。



发生下列情况时，请关闭电源。并从电源插座上拔下插头。

否则误踩下脚踏板时，缝纫机动作会导致受伤。

- 检查、调整和维修
- 更换旋梭，切刀等易损零部件



打开马达罩盖前，务必先关闭电源，等待一分钟后，再执行操作。

触摸马达表面可能会导致烫伤。



在必须接上电源开关进行调整时，请务必切换到保养模式。

务必十分小心遵守所有的安全注意事项。



缝纫机头倒下时，请一定要固定工作台，不可使其随意移动。

工作台移动易发生脚等被夹住之事故，是导致人身事故的原因。



缝纫机头倒下或竖起时，请用双手进行操作。

单手操作时因缝纫机的重量万一滑落易导致受伤。



更换零件或安装可选附件时，请务必仅使用正品零件。

本公司将不承担由使用非正品零件而造成的任何事故或故障责任。



取下的安全保护装置，再次安装时，请务必安装在原位上，并检查能否正常的发挥作用。



为了防止发生事故及故障，请勿擅自改造本缝纫机。

本公司将不承担由改造本缝纫机而造成的任何事故或故障责任。

Be careful

Sewing



This sewing machine is only used by persons trained in safe operation.



This sewing machine cannot be used for any purpose other than sewing.



Protective glasses must be worn when sewing machines are used.

If you don't wear protective glasses, there will be danger when you break the needle. The broken part of the needle may pop into your eyes and cause injury.



When the following happens, please cut off the power supply. Otherwise, when you step on the pedal, the sewing machine will cause injury.

·When the needle goes through the thread

·When changing needle or shuttle core

·When a sewing machine is not in use or when a person leaves the sewing machine



If a worktable with casters is used, the casters should be fixed so that they cannot move.



For the sake of completeness, please install protective device before using this sewing machine. If these safety devices are not installed, use sewing opportunities to cause personal injury and sewing machine damage.



During the sewing process, do not touch any moving parts or place the objects on the moving parts, because this will cause injuries to people or damage to the sewing machine.



When the head of the sewing machine falls down, please make sure that the worktable is fixed and not moved at will.

Accidents such as foot clamping have occurred in the movement of worktable, which is the cause of personal accidents



When the sewing machine head falls down or stands up, please operate with both hands.

One-handed operation can easily cause injury if the weight of the sewing machine slips.



If the sewing machine operates incorrectly, or hears abnormal noise or smells abnormal odor, the power supply should be cut off immediately. Then contact the shop or trained technicians.



If the sewing machine breaks down, please contact the shop or trained technicians.

Clean



Please cut off the power supply before starting the cleaning operation.

If you step on the pedal by mistake, the sewing machine will cause injury.



When the head of the sewing machine falls down, please make sure that the worktable is fixed and not moved at will. Accidents such as foot clamping have occurred in the movement of worktable, which is the cause of personal accidents.



When the sewing machine head falls down or stands up, please operate with both hands.

One-handed operation can easily cause injury if the weight of the sewing machine slips.



When lubricating oil and butter are used, it is necessary to wear protective glasses and gloves to prevent lubricating oil from falling into serious or sticking to the skin, which is the cause of inflammation.

In addition, lubricants or butter should not be drunk, otherwise vomiting and diarrhea will occur.

Keep oil out of reach of children

Maintenance And Inspection



Only trained technicians can repair, maintain and inspect sewing machines.



Maintenance, maintenance and inspection related to electricity should be entrusted to purchasing shops or electrical professionals.



Turn off the power supply when the following happens. Pull the plug from the power outlet.

Otherwise, when you step on the pedal, the sewing machine will cause injury.

·Inspection, adjustment and maintenance

·Replacement of fragile parts such as spindle and cutter



Before opening the motor cover, be sure to turn off the power supply, wait a minute, and then perform the operation.

Touching the motor surface can cause burns.



When the power switch must be connected to adjust, be sure to switch to maintenance mode.

Be careful to observe all safety precautions



When the head of the sewing machine falls down, please make sure that the worktable is fixed and not moved at will.

Accidents such as foot clamping have occurred in the movement of worktable, which is the cause of personal accidents



When the sewing machine head falls down or stands up, please operate with both hands.

One-handed operation can easily cause injury if the weight of the sewing machine slips.



When replacing parts or installing optional accessories, be sure to use only genuine parts.

The Company will not be liable for any accident or malfunction caused by the use of non-authentic parts.



When removing the safety protection device and installing it again, be sure to install it in situ and check whether it can work properly.



In order to prevent accidents and malfunctions, please do not alter the sewing machine without authorization.

The Company will not be liable for any accident or malfunction caused by the modification of the sewing machine.

[2] 警告标签

缝纫机上有列警告标签。

当使用缝纫机时，请遵守标签上的说明。如果标签脱落或模糊不清，请和购买商店联系。

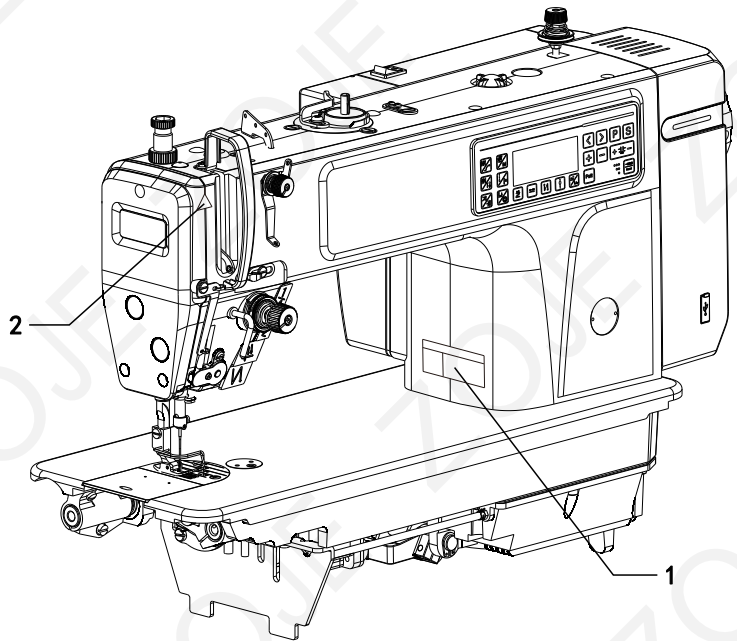
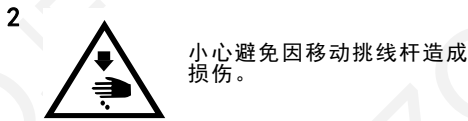
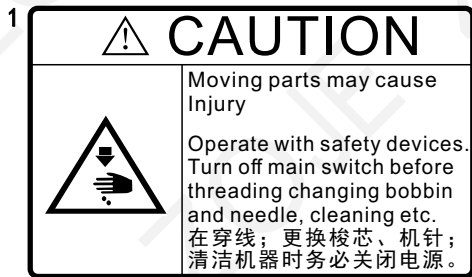

[2] Warning Label

The following warning labels are on the sewing machine

When using the sewing machine, please follow the instructions on the label. If the label falls off or is ambiguous, please contact the purchase shop.

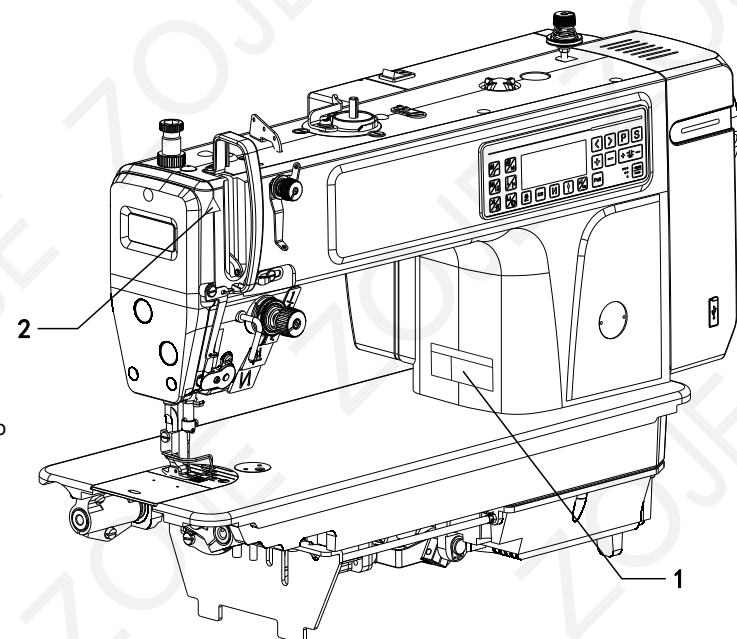
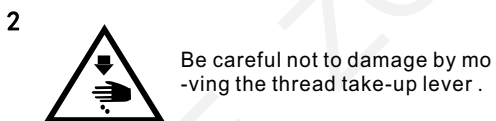
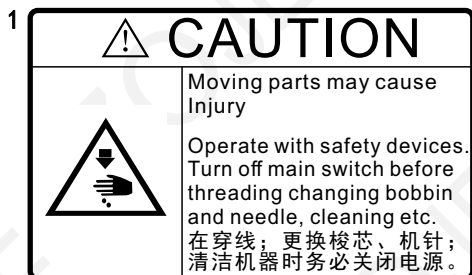

目 录

CONTENTS

使用说明

Operation Instruction

1	开车前的注意事项 Precautions Prior to Startup	3
2	使用注意事项 Precautions for Use	3
3	主要技术规格 Main Technical Specifications	4
4	机器的安装 Mounting the Machine	5
5	机器的加油 Lubrication of machine	5
6	线架的安装 Mounting the Thread Stand	6
7	机针的装法 Mounting the Needle	7
8	梭芯的装法 Mounting the Bobbin	7
9	梭芯套的装法 Installation of bobbin case	8
10	底线的卷绕 Winding up the Bobbin Thread	8
11	面线的穿法 Threading the Needle Thread	9
12	关于压脚提升 Lifting of presser foot	10
13	针距的调节 Adjusting the Stitch Length	11
14	手触倒缝装置的用法 Hand-touch Backstitch Device	11
15	踏板的操作 Operating the Treadle	12
16	踏板的调整 Adjusting the Treadle	12
17	旋梭油量调节 Oil mass Adjustment of Rotating Hook	14

18	压脚压力的调节 Adjusting the Presser Foot Pressure	15
19	压脚高度和角度的调节 Adjusting the height and angle of presser foot	16
20	自动抬压脚高度的调节 Automatic Adjustment of Presser Foot Height	17
21	缝线张力的调节 Adjusting the Tension of Stitch Thread	17
22	剪线后面线长度的调节 Adjustment of the Upper Thread Length after Trimming	18
23	挑线杆挑线量的调节 Adjusting the Take-up Amount of Take-up Lever	18
24	挑线弹簧的调节 Adjusting the Take-up Spring	19
25	针杆高度的调节 Adjust the Height of the Needle Bar	21
26	机针和旋梭同步的调节 Adjust the Synchronization of the needle and hook	22
27	机针和送料同步的调节 Adjust the Synchronization of the Needle and Feed	22
28	送料牙高度的调节 Adjustment of the Height of feed dog	23
29	送料牙倾斜的调节 Adjust the lean of feed dog	24
30	定刀和动刀的更换 Replacing the fixed knife and movable knife	25
31	剪线装置的调节 Adjusting the Thread-trimming Device	26
32	保养 Maintenance	27
33	缝纫机的搬运及放置注意事项 Carrying and Placing of the Sewing Machine	28

1 开车前的注意事项

Precautions Prior to Startup

1. 机头装箱前为了防止机件生锈,在部分均涂有较厚的防锈油脂,同时机头装箱后,还可能可能在较长的贮藏和长途运输阶段造成油脂硬化和在机器表面积聚灰尘,所以必须将表面的油脂和灰尘用汽油和洁净的软布擦拭干净。

2. 机器出厂时,虽经过周密的检查和试验,但在长途运输中也可能受到强烈的震动使机件松动或歪曲,所以应该做一次周密的检查,并用手转动上轮,看机件之间有无转动困难、碰撞现象或其它不均匀的阻力,不正常的声响,如有应作适当的调整,机器状态正常后才可正式试车。

3. 油箱内机油液面高度没有在正常范围内绝不能开车。

4. 机器运转时,上轮转向应该是逆时针方向(从上轮外侧面看)。

5. 确认电控铭牌上所标电压及相位是否正确。

6. 生产日期见合格证。

1.The machine head is coated with a thick layer of rust-prevention grease before encasement, and the encased machine head may possibly be subjected to grease hardening and dust buildup on the machine surface in process of long storage and long-haul traffic; therefore, take care to remove the grease and dust from the surface using soft cloth and gasoline.

2.Though the machine was inspected and tested with care before factory leaving, it might be affected by violent vibration resulting in looseness or distortion of the machine parts; therefore the operator shall thoroughly check the machine, turn the upper wheel by hand and check it for difficulty in free rotation, slight impact, and other uneven resisting force or abnormal noises, and make appropriate adjustment if any to restore the machine state before formal trial run.

3.Never start up the machine if the oil liquid level in the oil box falls outside the normal range.

4.The upper wheel shall rotate counterclockwise (when it is viewed from the lateral surface of the upper wheel) when the machine is operating.

5.Check whether the voltage and phases indicated on the electric-control data plate are correct.

6.The date of manufacture is indicated on the certificate of conformity.

2 使用注意事项

Precautions for Use

1. 当接通电源或机器运转时,请勿将手与机针接触。

2. 机器运转时,请勿将手指伸入挑线杆防护罩内。

3. 操作者用手送料时,请勿将手指伸入护针架。

4. 机头翻动及拆手盖时,一定要切断电源。

5. 操作者离开机器时,必须切断电源。
6. 机器运转时,绝不允许头或手以及任何东西靠近上轮、绕线器。
7. 只有在停机时,才能装卸防护罩或其它保护装置。
8. 不能用香蕉水等油漆稀释剂擦拭机头表面。

1.Never touch the needle by hand when the machine is powered on or while it is operating.

2.Never put your finger into the protection cover of take-up lever during operation of the machine.

3.The operator must not put his finger into the needle guard bracket when he feeds the sewing materials by hand.

4.Operator must trim off the electricity supply before he turns over the machine head or removes the hand cover.

5.The operator must trim off the electricity supply before he gets away from the machine.

6.Prohibit the head, hands and anything to approach the upper wheel and bobbin winder while the machine is operating.

7.Never remove or mount the protection cover or other protection devices before the machine is stopped.

8.Never wipe up the surface of machine head using paint thinner such as acetone.

3 主要技术规格 Main Technical Specifications

规格		参数
缝料		中厚料
最高缝速		5000针/分
最大针距		5-7毫米
机针		DB×19#~18#
压脚提升高度	手控	5.5毫米(最大)
	膝控	13毫米(最大)
润滑系统		自动
润滑油		10号白油
电机功率		220伏/550瓦

Specification		Parameter
Application		For medium-weight materials
Max sewing speed		5000sti/min
Max stitch length		5-7mm
Needle		DB×19#~18#
Presser foot lift height	Hand lifter	5.5mm(Max)
	Knee lifter	13mm(Max)
Lubricating system		Auto
Lubrication oil		10# White oil
Motor power		220V/550W

4 机器的安装 (图1、图2、图3) Mounting the Machine (Fig.1, Fig. 2 and Fig.3)

1. 油盘和机器的安装

1) 如右图所示将油盘②安装在台板①底下，并用6颗油盘固定螺钉③固定。

2) 如图所示将两只机头座垫④和两只机头支座⑤分别安装在台板①4个角上，再将机头连接钩座⑥安装在台板上，然后再用钉子固定在台板上。

3) 将机头连接钩⑦插入底板销孔内，对准机头连接钩座，把机头放到台板①四角的机头座垫上。

4) 如图所示将机头支柱⑧牢牢地插入台板中。

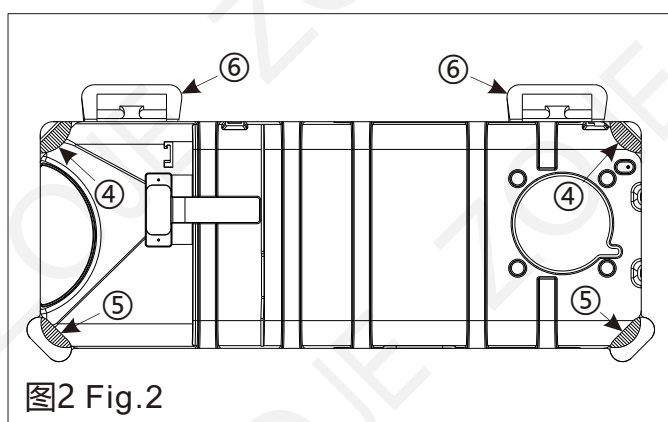
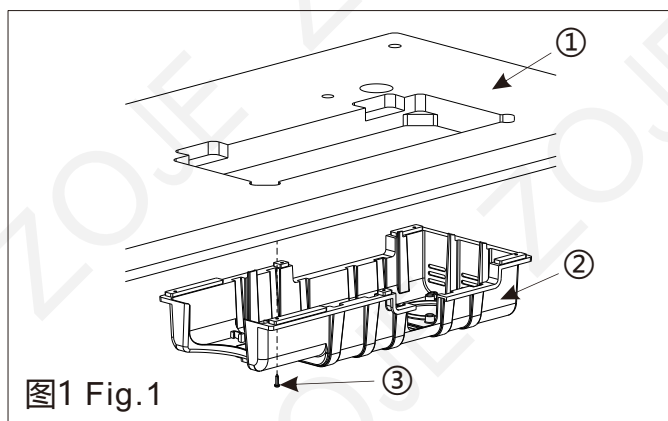

1. Installation of oil pan and machinery

1) As shown in the picture on the right, fix oil pan ② under the machine table ① with 6 fixed screws ③.

2) As shown in the picture, fix tow head cushions ④ and two head support seats ⑤ in four corner of the machine table ① respectively, then fix connecting head hook seat ⑥ on the machine table with 6 screws.

3) Insert the head connect hook ⑦ in the pin hole of baseboard, align head connect hook seat, then put head in four corners of head cushion in the machine table ①.

4) As shown in the picture, insert head support ⑧ into the machine table firmly.

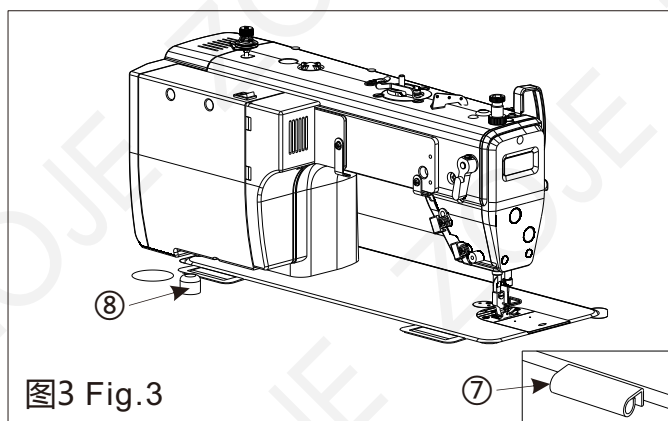

5 机器的加油(图4) Lubrication of machine(Fig.4)

1. 机器齿轮箱的加油

使用缝纫机时，如果油标杆②指到油标窗③的下刻线以下时，请对机器齿轮箱进行加油。

加油步骤如下：

1. Lubrication of gearbox

Fill gearbox if the oil pointer ② below the lower tick mark in the oil window ③ when using the sewing machine.

The steps of lubrication are as follow:

1) 卸下加油口的橡胶塞①，使用自带的加油壶加入缝纫机油(10号白油)。

2) 请把油加满至油标杆②指到油标窗③的上刻线位置。请注意加油过多的话，机器翻倒时，机油会流入机头。

3) 加完油后，装上加油口的橡胶塞①。



注意:



1.为了防止缝纫机的意外启动，请关掉电源之后再进行操作。

2.新机开始一次缝纫前，请卸下加油口的橡胶塞①，使用自带的加油壶加入500ml缝纫机油(10号白油)。



Caution:

1.To prevent the unexpected startup of sewing machine, trim off the power supply before the operation is conducted.

2.when using the new sewing machine for the first time, open the rubber plug ① of oil filler and fill with 200ml oil.(No.10 white oil)

1) Remove the rubber plug ① of oil filler, fill with oil using the oil bottle in accessory box.(No.10 white oil)

2) Fill oil until the oil pointer ② reaches the upper tick mark in the oil window ③. Do not fill too much oil otherwise the oil will flow into head when turnover machine.

3)Close rubber plug ① of oil filler after finishing lubrication.



图4 Fig.4

6 线架的安装(图5) Mounting the Thread Stand (Fig.5)

1.如右图所示那样将线架部件安装到缝纫机台板线架安装孔上。

2.旋紧线架杆下节固定螺母①固定线架。

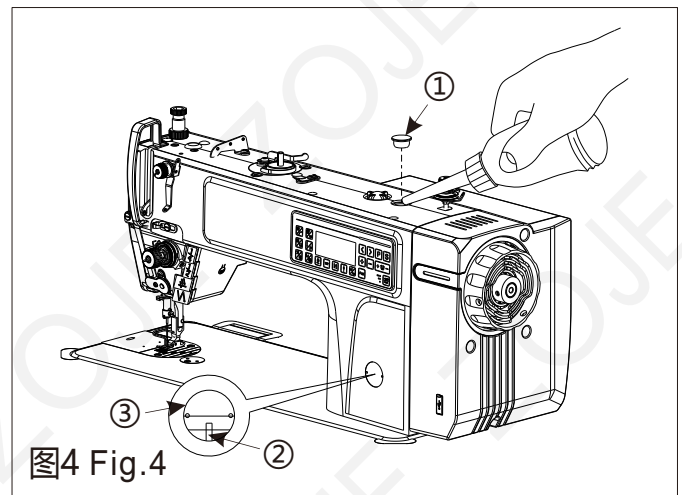
1.As shown in right-hand figure, mount the thread stand component onto the mounting hole for thread stand on the sewing machine table.

2.Screw down retaining nut ① for lower segment of thread stand lever to fix the thread stand.



图5 Fig.5



图6 Fig.6

7 机针的装法 (图6) Mounting the Needle (Fig.6)

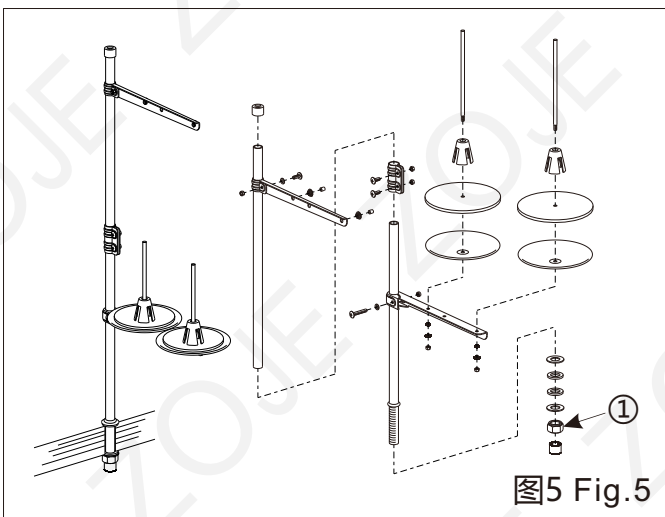
1. 转动上轮使机针上升到最高处。
2. 拧松支针螺钉②，手拿机针①将机针的凹弧部分A正对右方向B。
3. 将机针朝箭头方向插入针孔的底部，直至插不进为止。
4. 拧紧支针螺钉②。
5. 务必使机针的长槽C正对左方向D。

1. Turn the upper wheel to allow the needle to reach its maximum height.
2. Unscrew needle carrying screw ②, hold needle ① by hand, and align the indentation A of needle to right direction B.
3. Insert the needle into the bottom of needle hole in direction of arrow till it reaches the end point.
4. Screw down the needle carrying screw ②.
5. Take care to ensure that the elongated slot C on the needle is aligned to the left direction D.

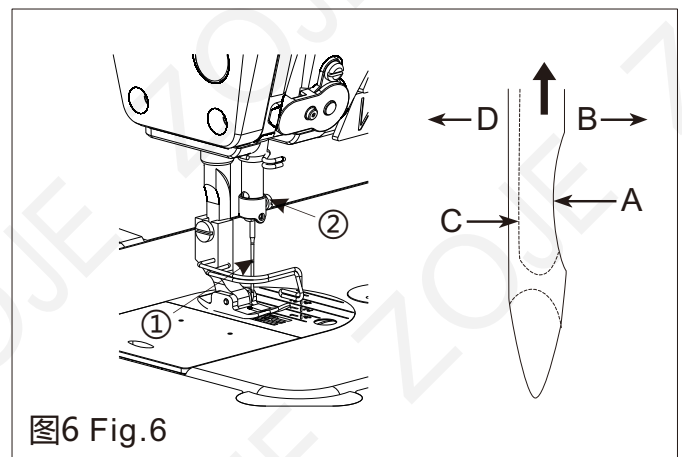

注意:

1. 为了防止缝纫机的意外启动，请关掉电源之后再进行操作。
2. 机针有各种编号，请根据所用线的粗细和缝料来选择适当的机针。



Caution:

1. To prevent the unexpected startup of sewing machine, trim off the power supply before the operation is conducted.
2. Needles are available in different sizes. Please select appropriate needle as per the thickness of threads and the sewing materials.



图7 Fig.7

8 梭芯的装法 (图7) Mounting the Bobbin (Fig. 7)

1. 拿住梭子，将梭芯装入梭子内。
 2. 将线从梭子上的线槽A中穿过，朝C方向拉出。这样，线通过夹线簧从孔B处引出。
 3. 拉底线时，梭芯应按箭头方向顺时针转动。
1. Hold the rotating hook by hand, and fit the bobbin into the rotating hook.
 2. Thread the thread through the thread groove A in the rotating hook, and draw out the thread in direction C. In this way, the thread is led out of hole B through the tension spring.
 3. When bobbin thread is drawn, the bobbin shall turn clockwise in direction of arrow.

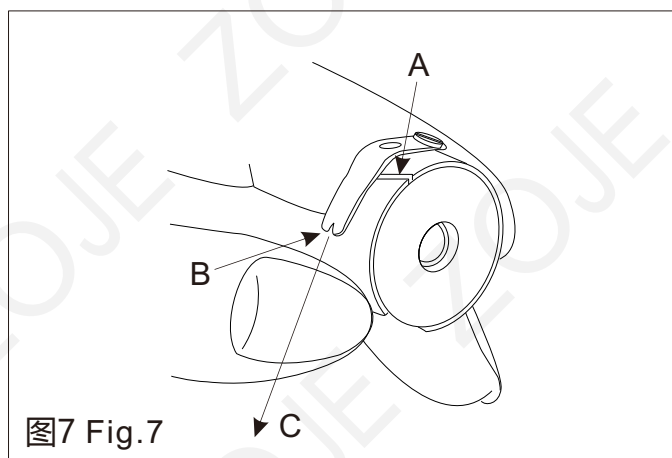

图8 Fig.8

9 梭芯套的装法 (图8)

Installation of bobbin case (Fig. 8)

1. 转动手轮将机针升起，直至其处于针板上方。
2. 用手拿住梭芯套①(装好梭芯)，将梭芯套装入旋梭中。

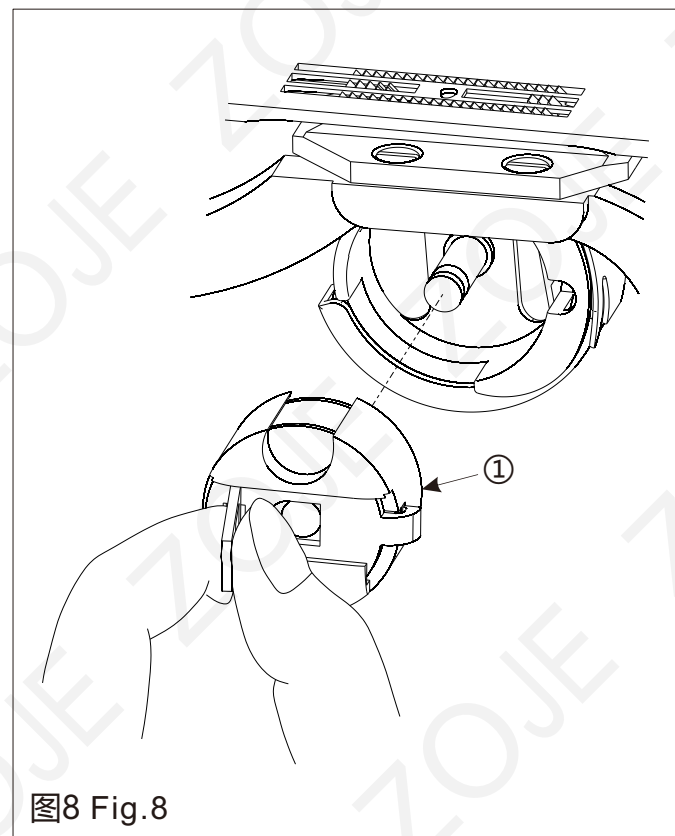
1. Turn the machine pulley to raise the needle until it is above the needle plate.
2. Hold the bobbin case ① (with bobbin) with one hand, then install the bobbin case into the hook.

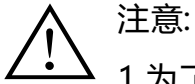

注意:



1. 为了防止缝纫机的意外启动，请关掉电源之后再进行操作。



Caution:



1. To prevent the unexpected startup of sewing machine, trim off the power supply before the operation is conducted.



图9 Fig.9



图10 Fig.10

10 底线的卷绕 (图9、图10)

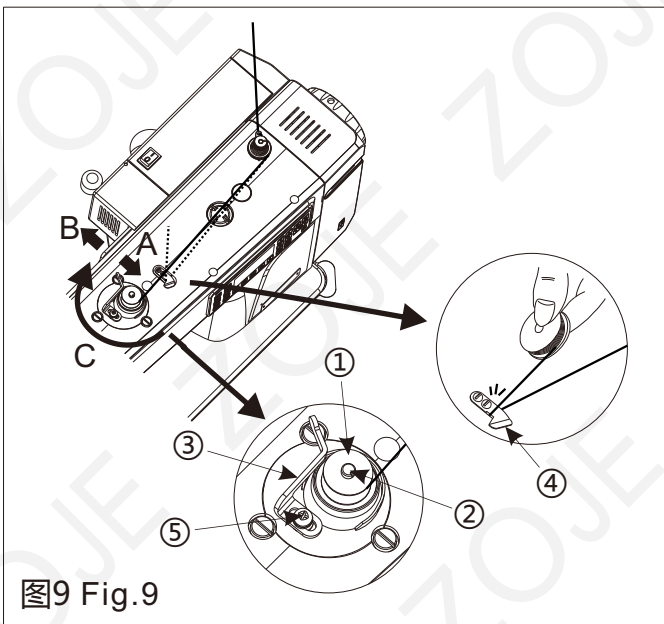
Winding up the Bobbin Thread (Fig. 9, Fig. 10)

1. 底线卷绕的方法
 - 1) 把梭芯①装到绕线轴②上。
 - 2) 把线架右侧的卷线如右图所示穿线，并把线端向右缠绕梭芯数圈。
 - 3) 把卷绕手柄③推到A方向，然后运转缝纫机。梭芯①向C方向转动，线卷绕到梭芯①上。卷绕线满后卷绕手柄③自动向B方向弹开并停止卷绕。
 - 4) 取下梭芯①，用绕线切刀④切断线。

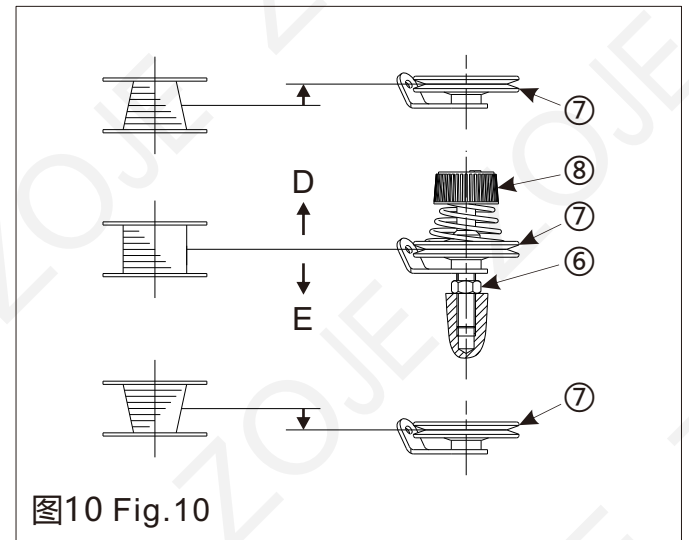
1. Bobbin thread winding-up method
 - 1) Fit bobbin ① onto spool ②.
 - 2) Thread the right-hand thread coiling on thread stand as shown in right-hand figure, and reel the thread end rightwards onto the bobbin for several turns.
 - 3) Push winding lever ③ over to direction A, and run the sewing machine. Bobbin ① is rotated in direction C, and thread is reeled onto bobbin ①. Once the reel is full, winding lever ③ is pushed toward direction B, and winding is over.
 - 4) Remove bobbin ①, and trim off the thread using winding trimmer ④.



注意:

1. 不进行缝制时给梭芯①绕底线时, 请把面线从挑线杆孔上抽出来, 把梭芯①从旋梭里卸下来后再进行。

2. 为了防止发生安全事故, 在底线卷绕的过程中, 不要碰触任何运动部件或将物件靠在运动部件上。

2. 底线卷绕的调节

1) 调整底线卷线量时, 请拧松固定螺钉⑤, 把卷线拨杆③移动到A方向或B方向, 然后再固定螺钉⑤。A方向卷线量变少, B方向卷线量变多。(注意: 卷绕在梭芯上的底线量最多应为梭芯容量的80%)

2) 如果线不能平绕梭芯时, 请拧松螺母⑥, 转动绕线夹线器, 调整夹线板⑦的高度:

a. 旋梭①中心和夹线板⑦中心高度一样时为标准位置。

b. 下部卷的多时, 向如右图D方向移动绕线夹线器的位置, 上部卷的多时, 向如右图E方向移动绕线夹线器的位置。

c. 调整绕线夹线器到合适位置后, 把固定螺钉⑥拧紧。

3) 调整底线卷绕张力时, 请转动线张力螺母⑧进行调整。

11

面线的穿法 (图11)

Threading the Needle Thread (Fig. 11)

穿面线时应先转动手轮使挑线杆上升到最高位置, 然后由线架上引出线头按图示序号顺序进行穿线。



注意:

1. 为了防止缝纫机的意外启动, 请关掉电源之后再进行操作。



Caution:

1. To reel bobbin thread onto bobbin ① when no sewing is performed, draw the needle thread out of hole in the take-up lever, remove bobbin ① out of rotating hook.

2. Do not touch or lean anything to any running components when rolling the bottom line, in order to avoid the safety accident.

2. Adjusting the bobbin thread winding

1) To adjust the winding capacity of bobbin thread, unscrew fixing screw ⑤, set winding lever ③ in direction A or direction B, and fix screw ⑤ again. Direction A is intended for reduction, and direction B is intended for increase (Caution: The amount of thread wound onto the bobbin should be a maximum of 80% of the bobbin capacity).

2) If thread cannot be wound onto the bobbin flatly, unscrew nut ⑥, turn the winding tension disco, and adjust the height of thread gripper plate ⑦.

a. The standard position is reached once the center heights of rotating hook ① and thread gripper plate ⑦ are identical.

b. If the winding amount on the lower part is bigger, move the winding tension disco in direction D indicated in the right-hand figure. If the winding amount on upper part is bigger, move the winding tension disco in direction E indicated in the right-hand figure.

c. When the winding tension disco reaches its suitable position, screw down fixing screw ⑥.

3) Adjust the winding tension of bobbin thread by turning thread tension nut ⑧.

Thread the needle thread when needle bar stays in its highest position, lead out the thread end from the thread stand, and conduct threading as per the serial numbers indicated in the figure.



Caution:

1. To prevent the unexpected startup of sewing machine, trim off the power supply before the operation is conducted.





图11 Fig.11

12 关于压脚提升 (图12、图13) Lifting of presser foot(Fig. 12, Fig. 13)

1.手控提升压脚

1) 停车后将压脚扳手①朝A方向转动使压脚抬起(压脚的抬起量约为5.5mm)。

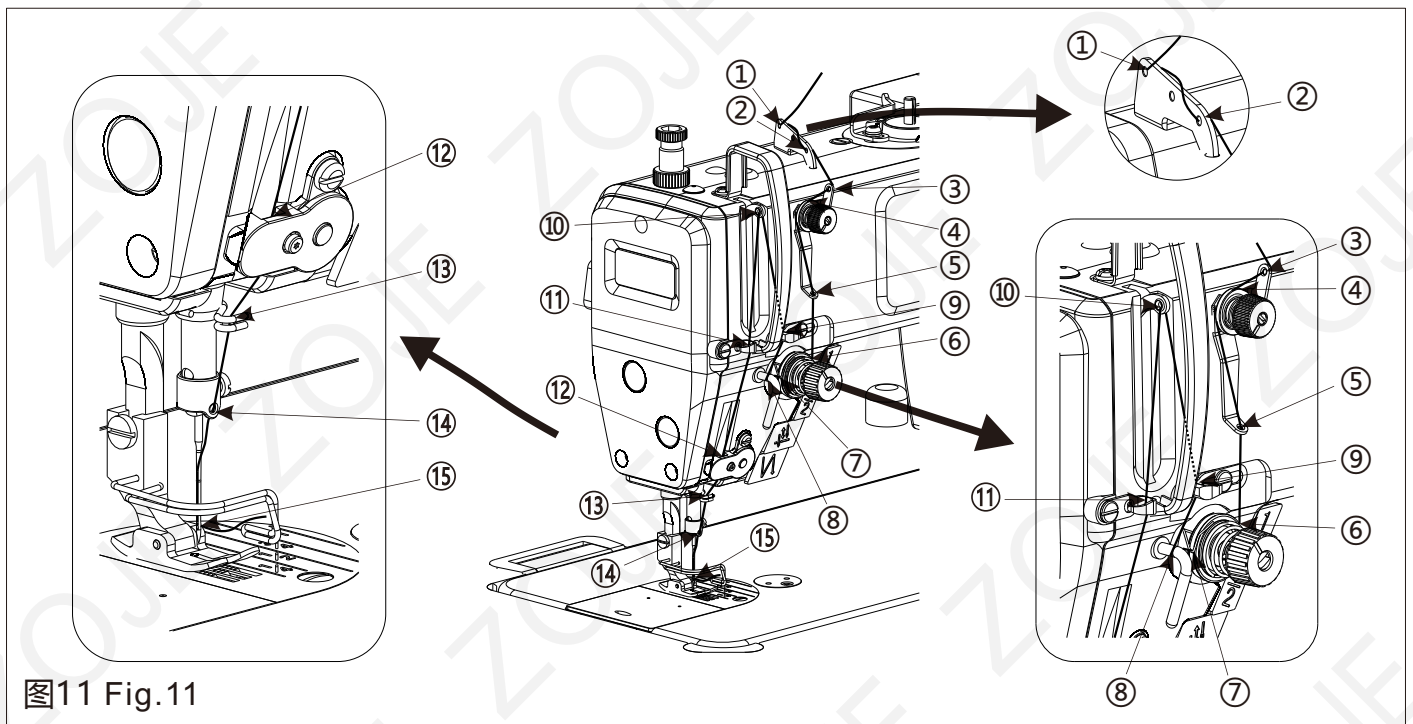
2) 当压脚扳手①朝B方向转动时, 压脚将放回原来的位置。

2.膝控提升压脚

1) 在压下膝控碰块②时, 可提升压脚③(压脚提升高度与膝控碰块压下程度有关)。

注意: 完全压下膝控碰块时, 压脚的标准提升量约为10mm, 最大提升量约为13mm。

2) 松开膝控碰块②后, 提升的压脚③立即放下。

1.Lift presser foot controlled by hands

1) Shut down the machine, turn presser foot lever ① in direction A to uplift the presser foot (for about 5.5 mm).

2) When presser foot lever ① is turned in direction B, presser foot will be returned to its original position.

2.Lift presser foot controlled by knees

1) The presser foot ③ can be raised by pressing the knee lifter plate ②. (Height of presser lifting is relate to the degree of knees pressing)

Caution: standard and maximal lifting height of presser foot are respectively about 10mm and 13mm when pressing knees fully.

2) The lifting presser foot ③ lowers as soon as loosing the knee lifter plate ② release.



图12 Fig.12



图13 Fig.13

13 针距的调节

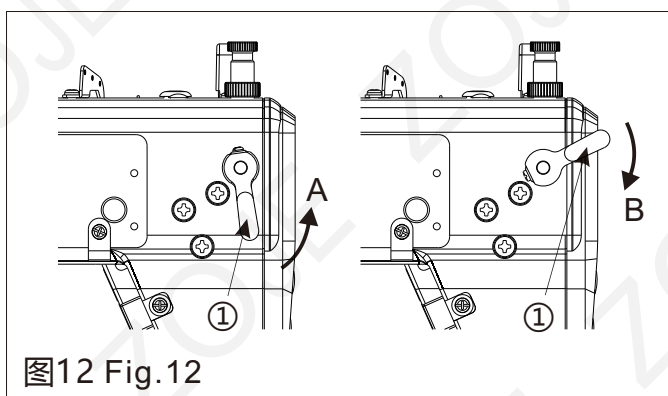
Adjusting the Stitch Length

针距已经由步进电机来控制，没有机械调整针距大小的功能，如需对针距大小进行调整，请直接调整操作面板上的针距大小，具体调整方法请参照电控使用说明书。

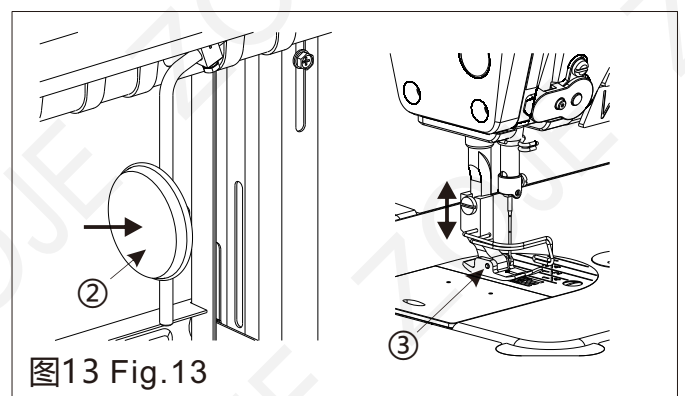
The stitch pitch is controlled by the stepper motor, and there is no mechanical function to adjust the stitch pitch. If you need to adjust the stitch pitch, please directly adjust the stitch pitch on the operation panel. For the specific adjustment method, please refer to the electronic control operation manual.

14 手触倒缝装置的用法 (图14)

Hand-touch Backstitch Device(Fig. 14)

1.倒缝按钮的使用方法

- 1) 按下倒缝按钮①，缝纫机立即开始倒缝。
- 2) 仅在按下的时间里进行倒缝。
- 3) 手松开后立即变为正向缝纫。

1. Use of back sewing push-button

- 1) Push the backstitch switching push-button ① to allow the sewing machine to start backstitch immediately.
- 2) Backstitch is implemented only while the push-button is held down.
- 3) It is changed to forward stitch once the push-button is released.

2.补针按键的使用方法

按一下全针距补针按钮②、1/2针距补针按钮③、1/4针距补针按钮④缝纫机则作往前补半针，一直按着缝纫机则作连续往前补针。

2. Use of reinforce sewing

Press the full needle pitch reinforce sewing button ②、1/2 needle pitch reinforce sewing button ③、1/4 needle pitch reinforce sewing button ④ one time, the sewing machine reinforce forth with half stitch, press all the time, it continues sewing with forth reinforce.

注意：补针按钮可在连续回缝除外，任何一种车缝中途停止时使用(未切线时)。

Caution:in addition to continue back reinforce sewing,the reinforce sewing bouton can be as stop button during any sewing condition.(before trimming)

3.照明灯控制按钮的使用方法

开机后照明灯会全亮度打开，按动照明灯控制按钮⑤，灯的亮度会依次减弱，直至关闭，依次循环。

3. Use of the light push-button

The illuminating lamp goes on at full brightness once the machine is powered on. Push illuminating lamp control button ⑤ to reduce in sequence the brightness till turn off.

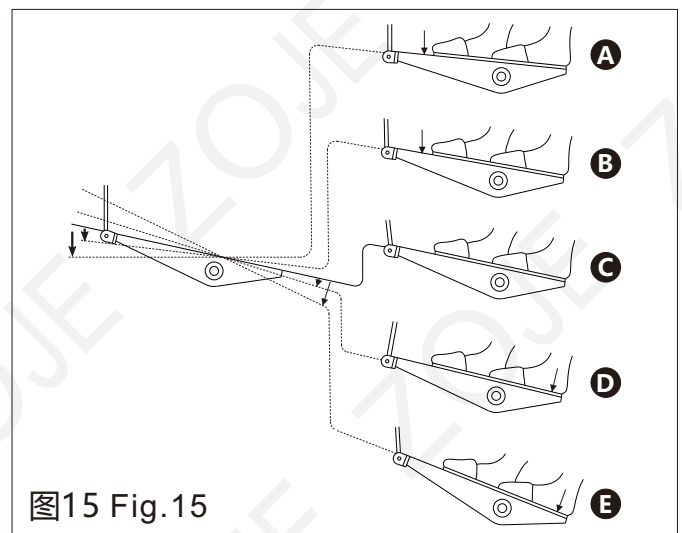
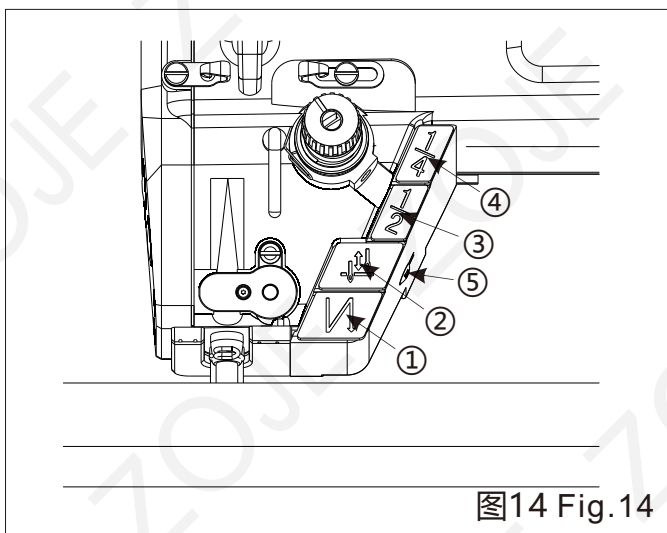

15 踏板的操作 (图15)

Operating the Treadle(Fig. 15)

1.踏板有4级操作:

- 1) 向前轻踩踏板为低速缝纫(图示B)。
- 2) 再用力向前踩踏板则变为高速缝纫(图示A)。
- 3) 当脚不向踏板施力, 则踏板回复到原始状态时, 缝纫机停止运转(机针在上停针或下停针位置)(图示C)。
- 4) 再用力向后踩踏板为切线动作(图示E)。
- 5) 使用自动压脚提升装置时, 在停止和切线之间增加一级开关D。向后轻踩踏板为压脚提升动作, 继续向后强力踩踏板, 压脚下降进行切线动作, 再次进行压脚提升动作。

1.The treadle has 4 operation levels:

- 1)The machine runs at low sewing speed when you lightly depress the front part of the pedal. (as show in the picture B)
- 2)The machine runs at high sewing speed when you further depress the front part of the pedal.(as show in the picture A)
- 3)Penal back to the initial position when stop stepping on it and the machine stop working.(needle in the upper or down position)(as show in the picture C)
- 4)The machine trims threads when you fully depress the back part of the pedal.(as show in the picture A)
- 5)When the auto-lifer is used,one more operating switch is provided between the sewing machine stop switch and thread trimming switch.The presser foot goes up when you lightly depress the back part of the pedal(D),and if you further depress the back part,the thread trimmer is actuated.



图16 Fig.16



图17 Fig.17

16 踏板的调整 (图16、图17、图18)

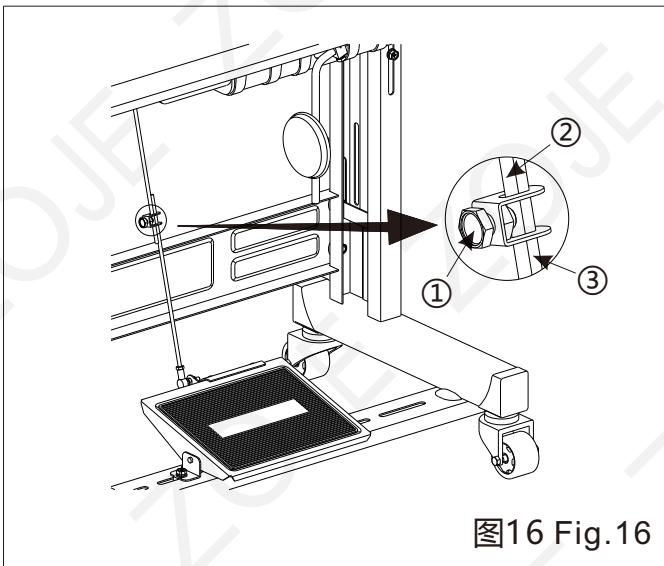
Adjusting the Treadle(Fig. 16, Fig. 17, Fig. 18)

1.踏板角度的调整

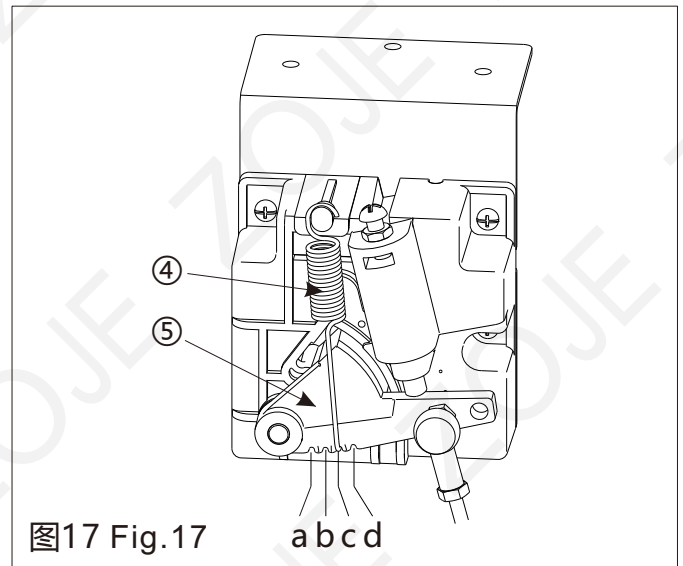
- 1) 调节踏板连接杆的长度即可以调节踏板的角度的: 旋松螺钉①, 上下移动上连接杆②和下连接杆③就可以调节踏板连接杆的长度。
- 2) 调节完成后旋紧螺钉①。

1.Adjusting the angle of treadle

- 1)Adjust the angle of treadle only by adjusting the length of treadle connecting rod: unscrew screw ①, and adjust the length of treadle connecting rod by moving upward/downward the upper connecting rod ② and lower connecting rod ③.



注意:

1.为了防止缝纫机的意外启动, 请关掉电源之后再进行操作。



2.踏板踩踏力的调整

将脚放在踏板上并向前轻踩踏板时, 缝纫机进行低速缝纫。如感觉踩踏力比较轻时, 将踩踏力调节弹簧④挂在踏板旋臂拨杆⑤的位置上进行调节(踩踏力以a为最小, b、c、d依次逐渐增大)。



注意:

1.为了防止缝纫机的意外启动, 请关掉电源之后再进行操作。



3.踏板返回力的调整

1) 松开螺母⑥, 旋转螺栓⑦调节踏板返回力: 拧紧螺栓⑦则踏板返回力将增大, 拧松螺栓⑦则踏板返回力将减小。

2) 调节完踏板返回力后, 请拧紧螺母⑥。



注意:

1.为了防止缝纫机的意外启动, 请关掉电源之后再进行操作。



4.踏板行程的调节

1) 拆下螺母⑧。

2) 将连杆接头⑨从A的位置移动到B的位置, 则踏板的行程变为原来行程的约1.3倍, 反之则踏板的行程变为原来行程的约0.8倍。

3) 调整完行程后, 请装上螺母⑧。



注意:

1.为了防止缝纫机的意外启动, 请关掉电源之后再进行操作。



2.踏板行程调整后, 踏板踩踏力和踏板返回力均已改变, 请按照上述步骤进行重新调整。

2)Screw down screw ① when adjustment is over.



Caution:

1. To prevent the unexpected startup of sewing machine, trim off the power supply before the operation is conducted.



2.Adjustment of the strength of pedal

The sewing machine run at a low speed when step forth on the panel slightly.If the strength is insufficient, hang the stepping adjustment spring ④ on the panel spiral arm driving lever ⑤ in order to adjust strength.(a is the minimum stepping strength ,b,c,d increase gradually)



Caution:

1. To prevent the unexpected startup of sewing machine, trim off the power supply before the operation is conducted.



3.Adjustment of stepping return strength

1)Loosing nut ⑥ and turn bolt ⑦ to adjust stepping return strength : tighten bolt ⑦,the strength increases;loosen bolt ⑦,the strength decreases.

2)Tighten nut ⑥ after adjusting stepping return strength.



Caution:

1. To prevent the unexpected startup of sewing machine, trim off the power supply before the operation is conducted.



图18 Fig.18

4. Adjustment of panel moving distance

- 1) Remove nut ⑧.
- 2) Move connecting rod joint ⑨ from A to B, panel moving distance is 1.3 times than original one. Move reversely the distance is 0.8 times as original one.
- 3) Assembly the nut ⑧ after adjusting panel moving distance.

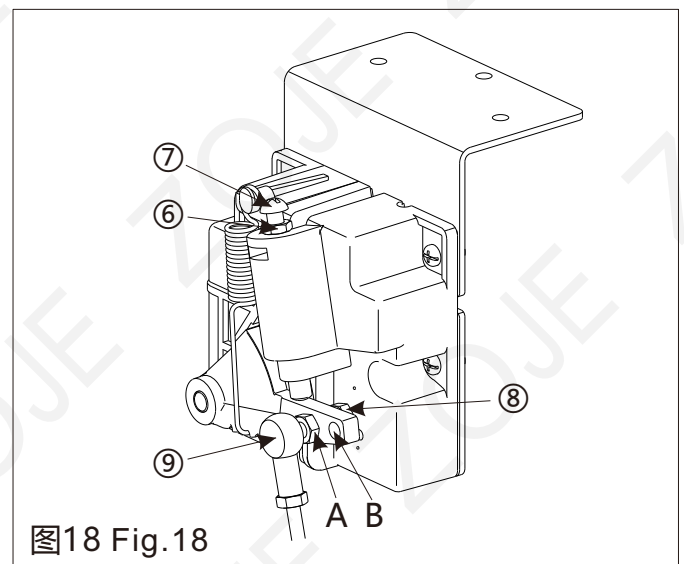

Caution:

1. To prevent the unexpected startup of sewing machine, trim off the power supply before the operation is conducted.
2. Stepping strength and stepping return strength both change after adjusting panel movement, follow the steps above to have adjustments again.



图19 Fig.19



图 21 Fig.21

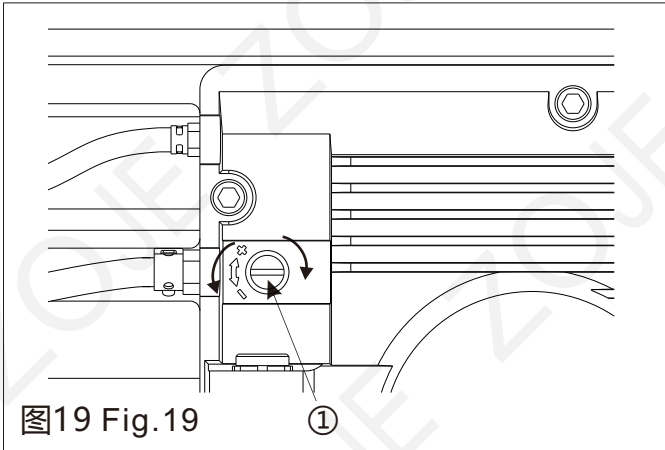

图20 Fig.20

17 旋梭油量调节 (图19、图20、图21) Oil mass Adjustment of Rotating Hook (Fig. 19, Fig. 20 , Fig. 21)

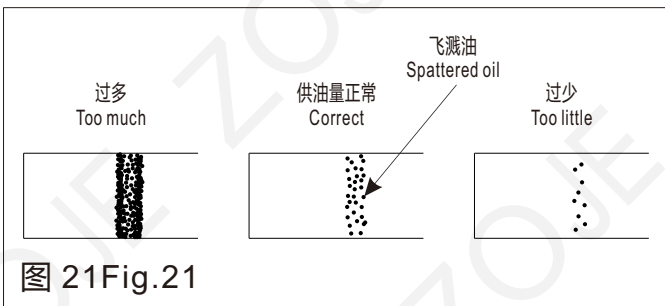
1. 调节方法

1) 旋梭的油量是用旋梭油量调节螺钉①来调节：拧紧(向右转动)旋梭油量调节螺钉①旋梭油量将增多，拧松(向左转动)旋梭油量将减少，直至获得适当的供油量为止。

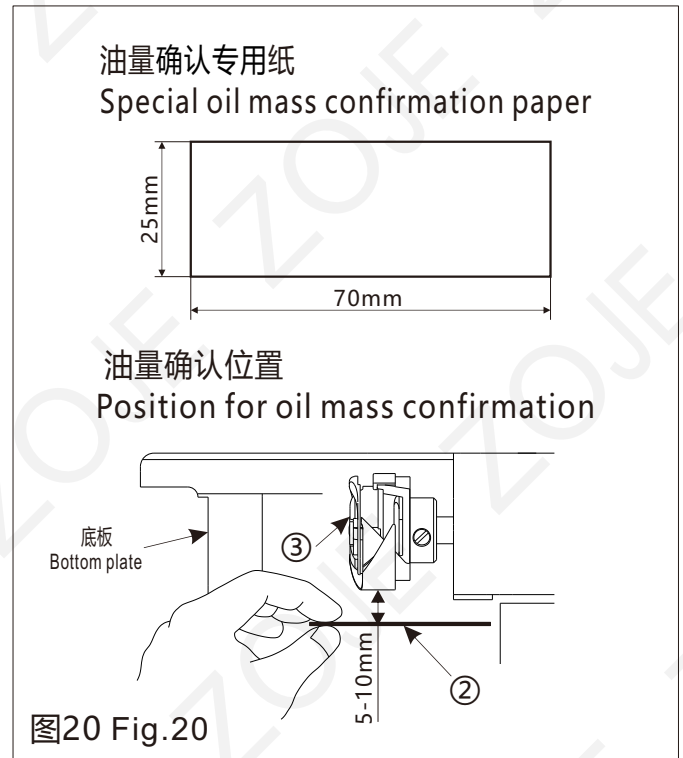
2) 调节油量后缝纫机在进行约2小时的缝纫后，再次检查以确认供油量。

1. Adjustment method

1) Adjust the oil mass of rotating hook using adjusting screw ①: Screw down (turn it to the right) adjusting screw ① to raise the oil mass ,or unscrew (turn it to the right) the adjusting screw to lower the oil mass.Amount repeatedly until the lubrication amount is correct.

2) Check the lubrication amount again after the sewing machine has been used for approximately two hours.



注意:

1. 为了防止缝纫机的意外启动，请关掉电源之后再进行操作。



Caution:

1. To prevent the unexpected startup of sewing machine, trim off the power supply before the operation is conducted.

2.油量的确认方法

- 1) 拆去挑线杆至机针上的面线。
- 2) 用抬压脚扳手抬起压脚。
- 3) 以缝纫机实际缝纫时的转速进行约3分钟的空运转(适度的断续运转)。
- 4) 将油量测试纸②插入旋梭③的下面并握住，以缝纫机实际进行缝纫时的转速使缝纫机运转10秒钟。(对油量测试纸②的纸质没有什么特别的要求)
- 5) 确认飞溅到测试纸②上的油量。



注意:



1.进行上述操作时，请卸下推板并确认油盒中是否有油。

2.为了防止发生安全事故，检查旋梭油量时，要充分注意手指不要碰到旋梭和送料机构等运动的零部件。

3.如更换了旋梭或要变更缝纫速度时，请按上述步骤调整旋梭供油量。

3.油量适合标样

- 1) 上图标样(见图22)可根据不同的缝纫工序需求进行增或减的微调整，但应注意不要增加或减少过多。油量过少时会引起旋梭发热，油量过多时会污染缝料。
- 2) 用油量测试纸测试3次，直至确认3次油量测试纸油迹均无变化为止。

2.Confirming the Oil Mass

- 1) Remove the thread from all points from the thread take-up to the needle.
- 2) Use the lifting lever to lift the presser foot.
- 3) Run the machine at the normal sewing speed for approximately 3 minute without sewing any material (following the same start stop pattern as when actually sewing)
- 4) Place the lubrication amount check sheet ② underneath the rotary hook ③ and hold it there. Then run the sewing machine at the normal sewing speed for 10 seconds. (Any type of paper can be used as the lubrication amount check sheet ②)
- 5) Check the amount of oil which has splattered onto the sheet ②.



Caution:



1. Prior to the above-mentioned operation, remove the knockout plate and check whether there is oil in the oil box.

2. Do not use fingers to touch the hook or other running components of feeding mechanism when checking the amount of oil for the hook to avoid the accident.

3. Use the following procedure to check the amount of oil being supplied to the rotary hook when replacing the rotary hook or when changing the sewing speed.

3. Guide sample of oil mass adequacy

1) The guide sample shown in the right-hand figure(see Fig. 22) may be finely adjusted (increased or reduced) as per different sewing processes; however, excessive increase or reduction shall be avoided. Too little oil mass may lead to rotating hook heating, and over much oil mass may lead to contamination of the sewing materials.

2) Test the oil mass 3 times using special oil mass confirmation paper till the oil traces indicated by the special paper show no changes.

18 压脚压力的调节 (图22) Adjusting the Presser Foot Pressure(Fig. 22)

1.旋松调压螺母②。

2.若将调压螺钉①朝顺时针方向(即A方向)转动时,压脚压力将增强;若朝逆时针方向(即B方向)转动时,压脚压力将减弱。

3.调节完成后旋紧调压螺母②。



注意:



1.为了防止缝纫机的意外启动,请关掉电源之后再进行操作。

2.对一般布料而言,调压螺钉①的标准高度为32~34毫米,(4.5公斤力)左右。

1. Unscrew pressure adjusting nut ②.

2. Presser foot pressure is increased if pressure adjusting screw ① is turned clockwise (namely in direction A); the pressure is reduced if the screw is turned counterclockwise (namely in direction B).

3. Screw down pressure adjusting nut ② when adjustment is over.



Caution:



1. To prevent the unexpected startup of sewing machine, trim off the power supply before the operation is conducted.

2. For ordinary materials, the standard height of pressure adjusting screw ① ranges from 32 to 34mm (4.5 kilogram force) approximately.



图22 Fig.22



图23 Fig.23

19 压脚高度和角度的调节 (图23) Adjusting the height and angle of presser foot(Fig. 23)

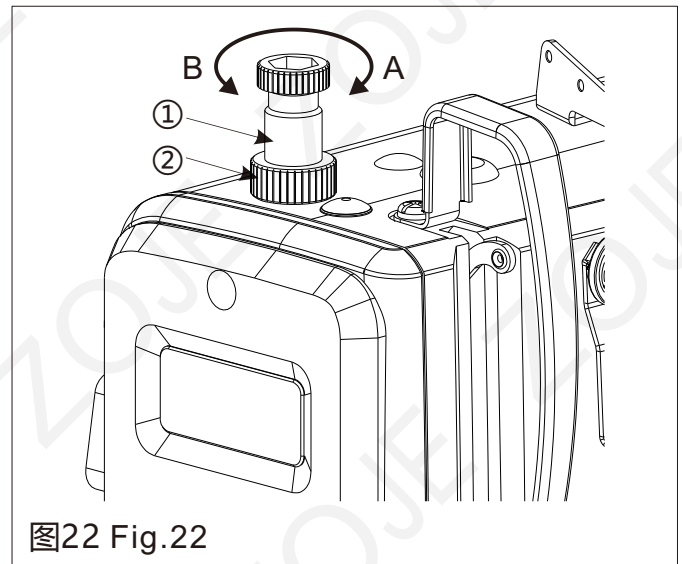
1.旋松调压螺母②和调压螺钉①,使其对压脚不施加压力。

2.拆下面板上的橡胶塞③。

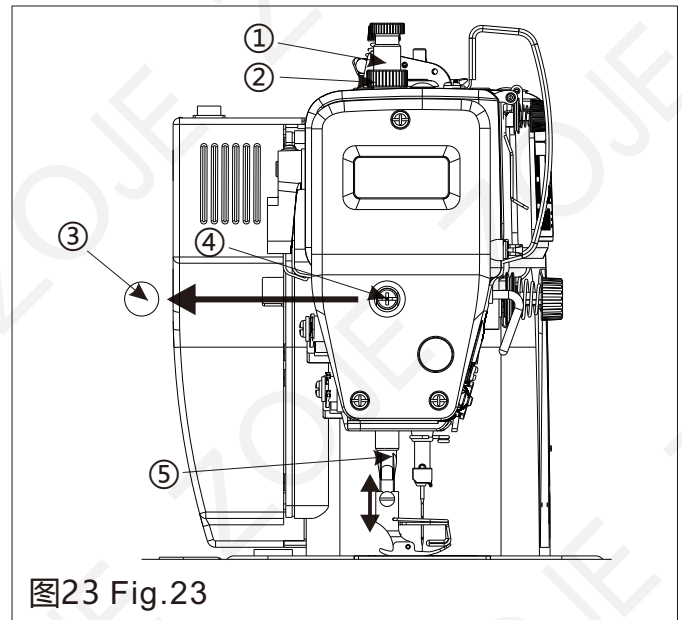
3.旋松压杆导架紧固螺钉④,上下移动压杆⑤来调节压脚的高度和角度(压脚高度为针板面与压脚底面的距离,手动抬压脚高度的标准值为5.5mm)。

4.调节完成后旋紧压杆导架紧固螺钉④,并装上橡胶塞③。

1. Loosen pressure adjusting nut ② and screw ①, free the pressure of presser foot.

2. Open rubber plug ③ in panel.

3. Loosen screw ④ in compression rod guide frame, move mobile compression rod ⑤ from up and down to adjust the height and angle of presser foot. (height of presser foot is the distance from needle plate surface to the bottom of it, the standard height of lifting presser foot by hand is 5.5mm)

4. Tighten the screw ④ in compression rod guide frame and assembly the rubber plug ③ after adjusting.

5.通过调压螺钉①来调节压脚压力，调节后并旋紧调压螺母②。

5.Adjust pressure of presser foot through pressure adjusting screw ①, tighten the nut ② after adjusting.



注意:



- 1.为了防止缝纫机的意外启动，请关掉电源之后再进行操作。
- 2.调节完成后回转手轮，确认机针应下降到压脚槽的正中处。



Caution:



- 1.To prevent the unexpected startup of sewing machine, trim off the power supply before the operation is conducted.
- 2.After adjusting,check that the needle moves down into the center of the groove in the presser foot.

20 自动抬压脚高度的调节 Automatic Adjustment of Presser Foot Height

自动抬压脚由步进电机来控制，如需对自动抬压脚高度进行调整，请直接调整操作面板上的抬压脚高度按键，具体调整方法请参照电控使用说明书。

The automatic presser foot lifting is controlled by a stepper motor. If you need to adjust the height of the automatic presser foot lifting, please directly adjust the presser foot lifting button on the operation panel. For specific adjustment methods, please refer to the electronic control user manual.

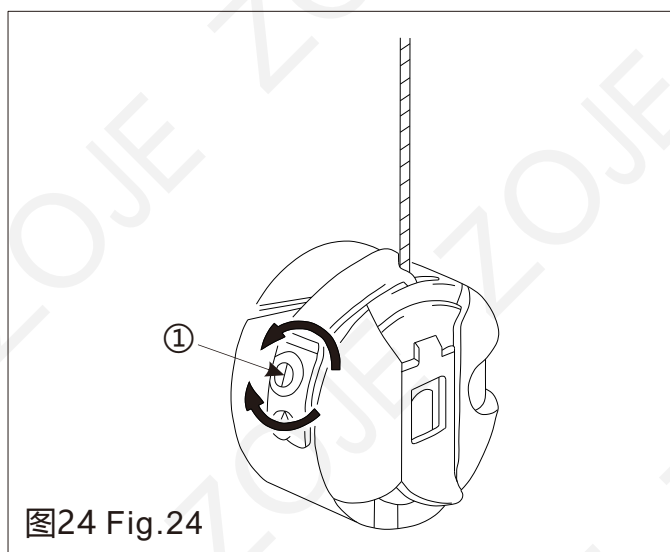

21 缝线张力的调节 (图24、图25) Adjusting the Tension of Stitch Thread(Fig. 24, Fig. 25)

1.底线张力的调节

拉住从梭芯套中露出的线头，旋转调节螺钉①进行调节：旋紧调节螺钉①则底线张力变大，反之则底线张力变小。

注意：底线张力调节标准：旋转调节螺钉①直至梭芯套以自重慢慢垂落。

2.面线张力的调节

在底线张力调节之后，调节面线张力以使针脚均匀平整。

- 1) 使用压脚扳手将压脚放下。
- 2) 转动夹线螺母②进行调节：朝顺时针方向

1.Adjusting the tension of bobbin thread

Hold the end of a thread which hanging from the bobbin case and use the adjusting rotating screw ① to regulate. The tension of the bottom thread is become strong by tight the screw ①, loose the screw to make it weak.

Caution : The adjust standard of the bottom thread tension: Rotating the adjusting screw ① till the bobbin case can falling slowly by it's own weight.

2.Adjusting the tension of needle thread

After the lower thread tension has been adjusted,adjust the upper thread tension so that a good,even stitch is obtained.

- 1)Lower the presser foot by using the lifting lever.
- 2)Adjust by turning the tension nut ② : The

(即A方向)转动时, 面线张力将增大; 朝逆时针方向(即B方向)转动时, 面线张力将减小。

tension of the upper thread will become strong when turning toward the clockwise(A), otherwise weak when toward anti-clockwise (B).



注意:

1.为了防止缝纫机的意外启动, 请关掉



电源之后再进行操作。



Caution:

1.To prevent the unexpected startup of sewing machine, trim off the power supply before the operation is conducted.



图25 Fig.25



图26 Fig.26

22 剪线后面线长度的调节 (图26) Adjustment of the Upper Thread Length after Trimming(Fig. 26)

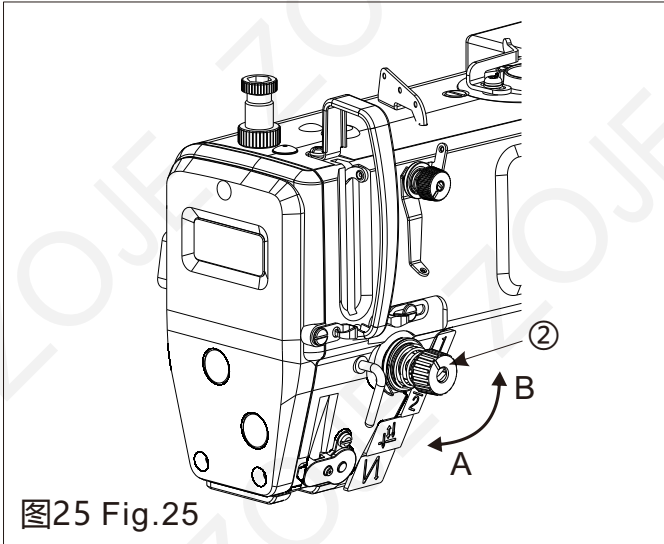
剪线时, 线张力松弛, 仅用上夹线器①施加张力。如果增加上夹线器①的张力, 剪线后残留在针孔处面线长度将会减少, 反之减小张力, 长度将会增加。

1.转动夹线器①上的调节螺母②进行调节: 朝顺时针方向(即A方向)转动时, 剪线后残留在针孔处面线长度将会减少,反之朝逆时针方向(即B方向)转动时, 长度将会增加(剪线后残留在针孔处面线标准长度: 25-30mm)。

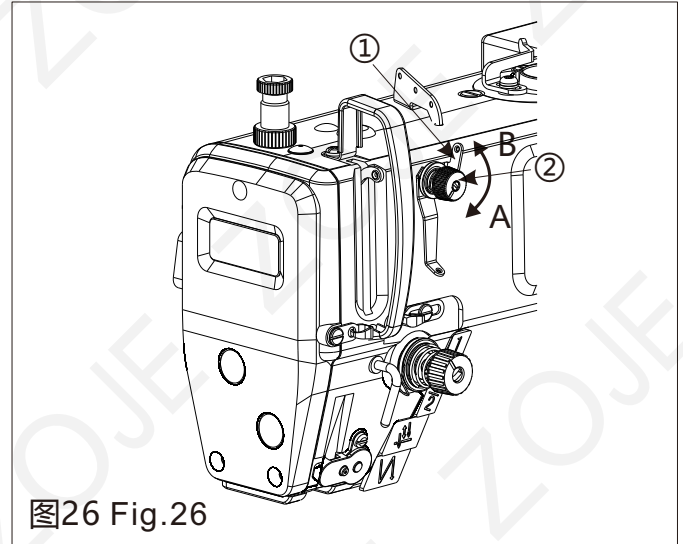
At the time of thread trimming, the thread tension is loosened and tension is applied by the thread clamp ① only. If added the tension in the thread clamp ①, the upper thread length that left in the pinhole will be shorter, and vice versa.

1.The length of upper thread which left in the pinhole will decrease when turning the adjusting nut ② in the thread clamp ① towards the clockwise (A), otherwise it will increase when turn toward anti-clockwise (B). (The standard length of the upper thread which left in the pinhole is 25~30mm)

23 挑线杆挑线量的调节 (图27) Adjusting the Take-up Amount of Take-up Lever(Fig. 27)

1. 旋松螺钉①。

2. 移动右线钩②进行调节：朝左方向(即A方向)移动，挑线量将会增加；反之朝右方向(即B方向)移动，挑线量将会减少。(右线钩上的刻线C与螺钉中心一致时为标准位置)。

3. 调节完成后拧紧螺钉①。



图27 Fig.27



注意:

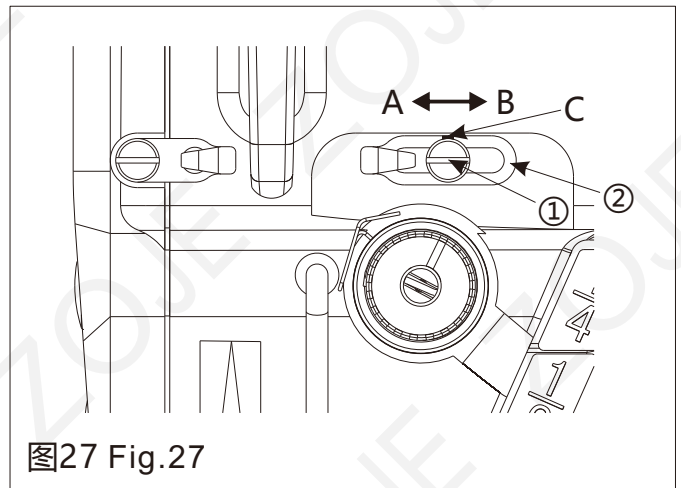

1. 为了防止缝纫机的意外启动，请关掉电源之后再进行操作。

2. 缝制厚料时，应按照上述方法向左方向移动右线钩②，以增大挑线量。

3. 缝制薄料时，应按照上述方法向右方向移动右线钩②，以减小挑线量。

1. Unscrewing the screw ①.

2. Move the right thread hook ② to adjust : the thread amount of thread take-up lever will increase if turned it towards left (A direction), while turning it to the right (direction B) and the thread amount of thread take-up lever will decrease accordingly. (The standard position is obtained when graduation line C on right thread hook is aligned to screw center.)

3. Remember to tight the screw ① after adjusting.



Caution:

1. To prevent the unexpected startup of sewing machine, trim off the power supply before the operation is conducted.



2. For heavy duty , move the right thread hook ② to left to add amount of thread.

3. For light material , move the right thread hook ② to right to reduce amount of the thread.



图28 Fig.28

※挑线簧一直动作到最后
※The take-up spring keeps on functioning till the end.

※挑线簧的张力过强，所以在动作中途面线从B处就被拉出来。
※The tension of take-up spring is too high, so needle thread is drawn out of place B in process of the action.

24 挑线弹簧的调节 (图28) Adjusting the Take-up Spring (Fig. 28)

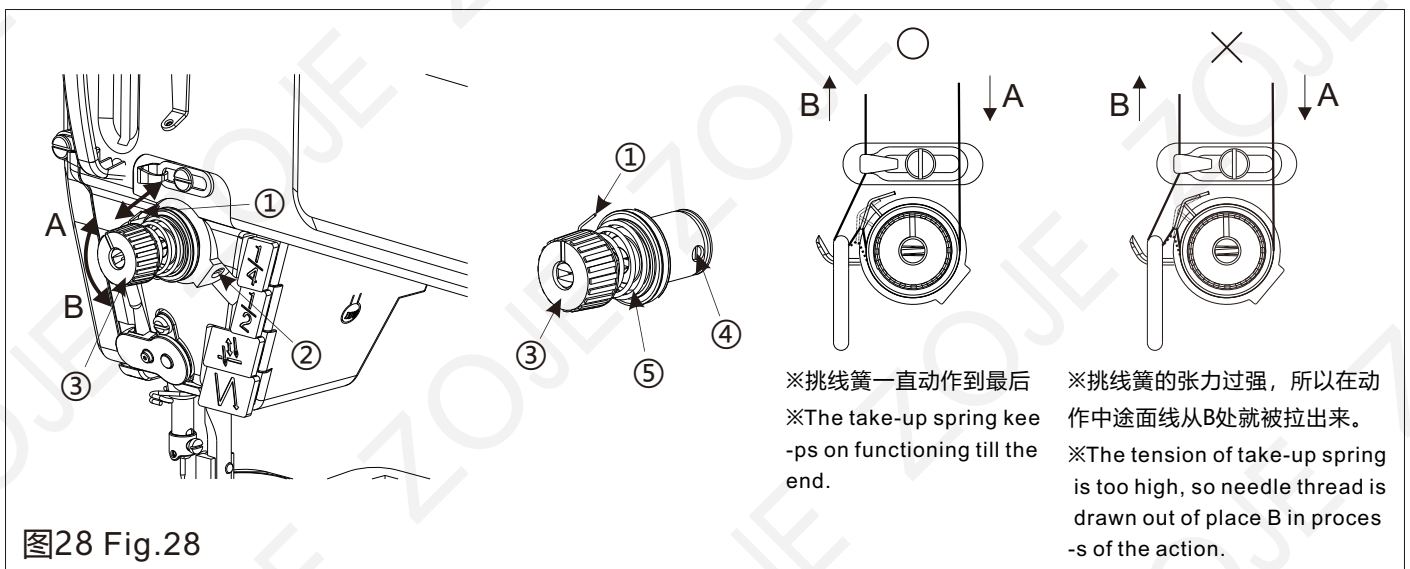
1.挑线簧张力的调节

- 1) 旋松螺钉②，取出夹线器⑤(组件)。
- 2) 旋松夹线器⑤中螺钉④。
- 3) 转动夹线器⑤中的螺钉③进行调节：朝顺时针方向(即A方向)转动时，挑线簧的张力将增大；反之朝逆时针方向(即B方向)转动时，挑线簧的张力将减小。

4) 调节完成后旋紧螺钉④，并将夹线器⑤(组件)装入机器中再旋紧螺钉②。

挑线簧张力调整适当的判断方法：确认挑线簧的张力调整后，把面线向B方向拉出，如果在挑线簧达到最低位置之前面线B处就被拉动，请减弱挑线簧的张力。



注意:



- 1.为了防止缝纫机的意外启动，请关掉电源之后再进行操作。
- 2.通常，机器在出厂前挑线簧均已调整妥善，只是在缝纫特殊的缝料或特殊的缝线时，才需要重新进行调整。

2.挑线弹簧挑线行程的调节

- 1) 使用压脚扳手将压脚放下。
- 2) 旋松紧固螺钉②。
- 3) 转动夹线螺钉③进行调节：朝顺时针方向(即A方向)转动时，挑线弹簧①的挑线行程将增加,反之朝逆时针方向(即B方向)转动时，挑线行程将减少(标准挑线行程：在压脚被放下的状态下，距离缓线钩上方6-7mm)。
- 4) 调节完成后拧紧紧固螺钉②。

1.Adjusting the tension of take-up spring

- 1)Unscrew screw ②, and take out thread clamp ⑤(assembly).
- 2)Unscrew screw ④ in thread clamp ⑤.
- 3)Rotating the screw ③ in the thread clamp ⑤ to adjust, The tension of the thread take-up spring will become larger when turning toward the clockwise(A), otherwise smaller when turning anti-clockwise (B).

4)Screw down screw ④ when adjustment is over, fit thread clamp ⑤(assembly) into the machine,and screw down screw ②.

Judgment basis for adjustment adequacy of take-up spring:Confirm that the tension of take-up spring is properly adjusted, draw out the needle thread in direction B. If place B of needle thread is drawn before take-up spring reaches its lowest position, reduce the tension of take-up spring.



Caution:



- 1.To prevent the unexpected startup of sewing machine, trim off the power supply before the operation is conducted.
- 2.The take-up spring is already adjusted properly before the machine leaves the factory as a rule, and it requires readjustment only for sewing of special materials or usage of special stitch threads.

2.Adjustment of the Stroke to the Thread take-up Spring

- 1)Lower the presser foot by using the lifting lever.
- 2)Loosen the set screw ②.
- 3)Rotating the screw ③ in the clamp to adjust, the stroke to the Thread take-up Spring ① will increase when turning toward the clockwise(A), otherwise decrease when turning anti-clockwise (B).(The standard stroke, under the state of presser foot was put down is around 6~7mm higher than the slow hook)
- 4).Securely tighten the screw ②.



注意:

1.为了防止缝纫机的意外启动, 请关掉电源之后再进行操作。



2.通常, 机器在出厂前,挑线簧均已调整妥善, 只是在缝纫特殊的缝料或特殊的缝线时, 才需要重新进行调整。



Caution:

1.To prevent the unexpected startup of sewing machine, trim off the power supply before the operation is conducted.



2.The take-up spring is already adjusted properly before the machine leaves the factory as a rule, and it requires readjustment only for sewing of special materials or usage of special stitch threads.



图29 Fig.29

25 针杆高度的调节 (图29) Adjust the Height of the Needle Bar(Fig. 29)

1.转动手轮, 使针杆①降到最低点。

2.拆下面板上的橡胶塞②。

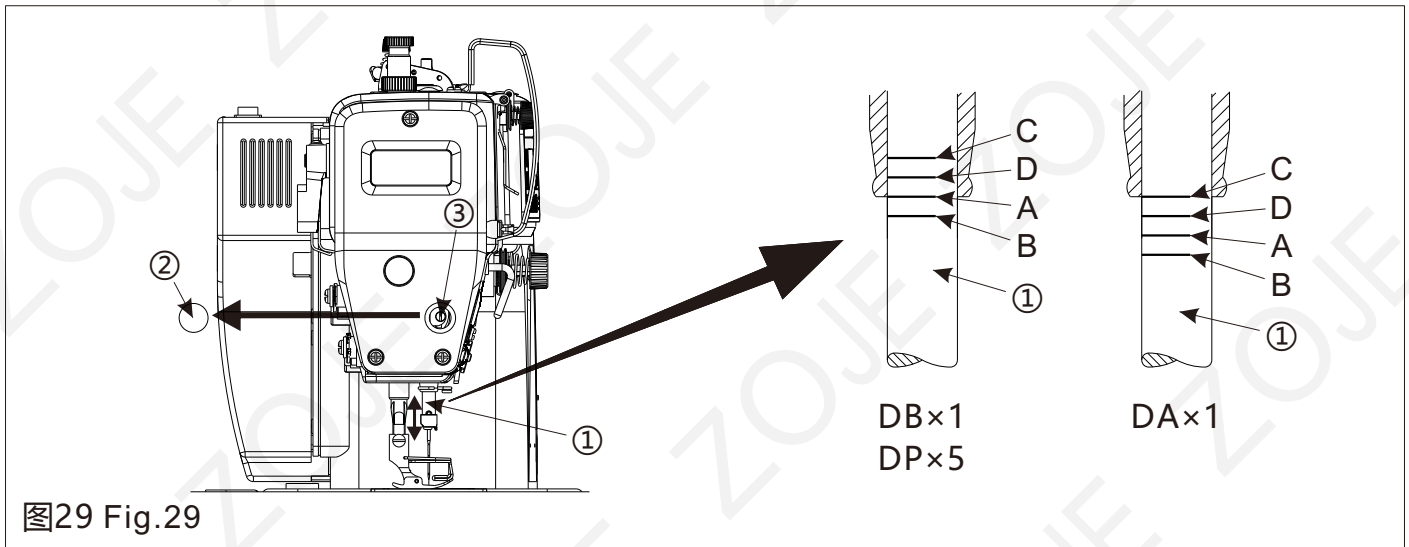
3.旋松针杆连接柱紧固螺钉③, 将针杆①上下移动来进行调节: 使用DBX1和DPX5机针时, 使针杆①上的刻线A对准针杆下套的下端; 使用DAX1机针时, 使针杆①上的刻线C对准针杆下套的下端。

4.调节完成后拧紧针杆连接柱紧固螺钉③, 并装上橡胶塞②。

1.Turn the machine pulley to set the needle bar ① to its lowest position.

2.Remove the rubber cap ② from the face plate.

3.Unscrewing the connecting screw ③ of needle bar, through moving the needle bar ① up and down to adjust, when using needle DBX1 and DPX5, the mark A on the needle bar ① should be match to the bottom of needle bar lower bushing; When using DAX1, the mark C on needle bar ① should match to the bottom of needle bar lower bushing.

4.Tighten the screw ③ in compression rod guide frame and assembly the rubber plug ② after adjusting.



注意:

1.为了防止缝纫机的意外启动, 请关掉



电源之后再进行操作。



Caution:

1.To prevent the unexpected startup of sewing machine, trim off the power supply before the operation is conducted.



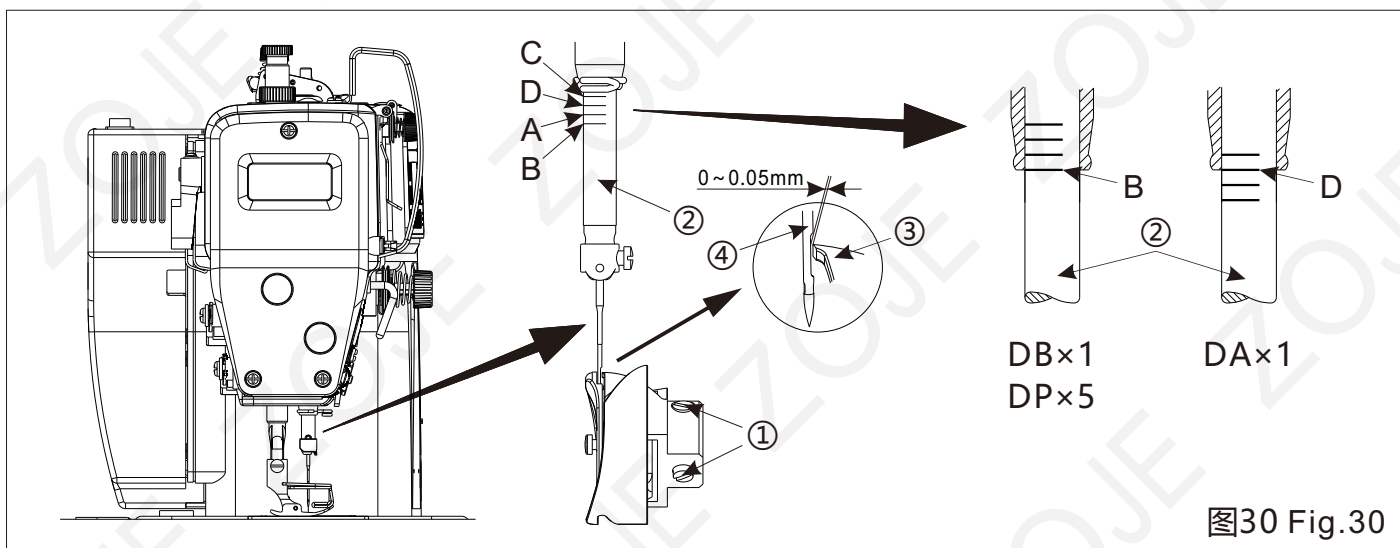

26 机针和旋梭同步的调节 (图30) Adjust the Synchronization of the needle and hook(Fig. 30)

1. 旋松2只旋梭定位螺钉①。
2. 转动手轮，使针杆②从最低点向上升起：使用DBX1和DPX5机针时，使针杆②上的刻线B对准针杆下套的下端；使用DAX1机针时，使针杆②上的刻线D对准针杆下套的下端。
3. 移动旋梭使旋梭的梭尖③和机针④缺口处的中心保持一致。此时，应使旋梭梭尖③和机针④之间的间隙为0-0.05mm。
4. 调节完成后拧紧2只旋梭定位螺钉①。

1. Unscrewing the two positioning screw ① of hook.
2. Rotating the hand wheel to make needle bar ② lift from the lowest place, when using needle DBX1 and DPX5, the mark B on needle bar ② should match to the bottom of lower needle bar ② bushing, when using needle DAX1, the mark D on needle bar ② should match to the bottom of lower needle bar ② bushing.
3. Moving the hook to match the hook point ③ with center of needle ④. Meantime, make the space between the hook point ③ and needle ④ 0~0.05mm.
4. Tightening two positioning screw ① of hook.

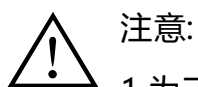

注意:



1. 为了防止缝纫机的意外启动，请关掉电源之后再进行操作。

2. 若机针与旋梭梭尖的间隙太小，会磨损旋梭梭尖；若间隙过大，会引起跳针。

3. 若旋梭坏损了，请更换相同型号的旋梭。



Caution:



1. To prevent the unexpected startup of sewing machine, trim off the power supply before the operation is conducted.

2. If the clearance between notch on needle and thread hooking tip of rotating hook is too small, rotating hook tip may be worn; if the clearance is excessive, skipped stitch may take place.

3. It may lead to needle breakage if over-rotating the eccentric wheel towards A direction.

27 机针和送料同步的调节 (图31) Adjust the Synchronization of the Needle and Feed(Fig. 31)



图31 Fig.31

1.取下橡胶塞①。

2.旋松送料偏心轮②上的两个固定螺钉③，然后轻微的旋转送料偏心轮②进行调节：要使机针早于送料时，向A方向旋转；要使机针晚于送料时，向B方向旋转(标准调节位置：送料牙从最高位置开始下降到和针板的表面一致时，机针孔上沿与针板面对齐)。

3.调节完成后拧紧2个固定螺钉③，并装上橡胶塞①。

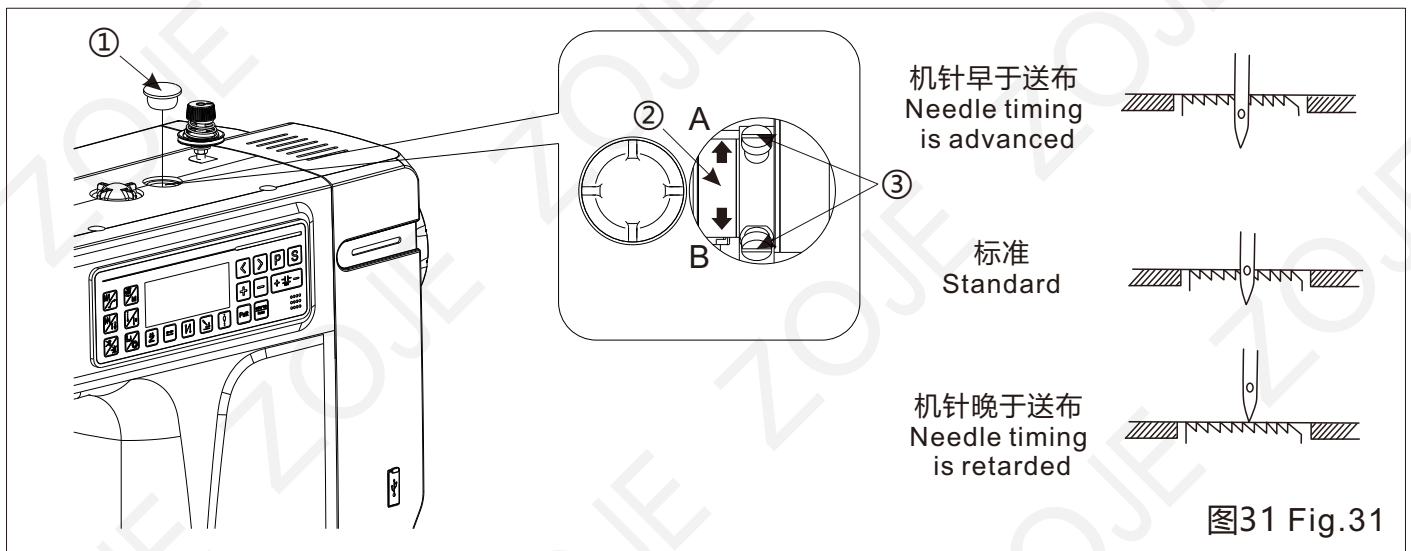

注意:



1.为了防止缝纫机的意外启动，请关掉电源之后再进行操作。

2.如果将送料偏心轮②沿A方向旋转过多，则有可能导致机针断裂。

3.为了防止在重叠缝纫时布料不一致(缝线不合)，可将机针的时序调晚些。

4.为了使收线良好，可将机针的时序调早些。

1.Remove the rubber plug ①.

2.Loosen the two set screws ③ of the feed eccentric cam ②, and then turn the feed eccentric cam ② slightly to adjust the timing: If make the needle sooner than material feeding, rotate toward A direction. If make the needle later than material feeding, rotate toward B direction. (The standard of adjustment is when the feed dog falling from the highest to the surface of needle plate, the top of the needle and needle plate should at the same level).

3.Tightening two positioning screw ③ and assembly the rubber plug ① after adjusting.



Caution:



1.To prevent the unexpected startup of sewing machine, trim off the power supply before the operation is conducted.

2.If the feed lifting eccentric cam ② is turned too far in the direction A, it may cause the needle to break.

3.To prevent material slippage from occurring, retard the needle timing.

4.To improve thread tightening, advance the needle timing.

28 送料牙高度的调节 (图32)

Adjustment of the Height of feed dog(Fig. 32)

1.转动手轮，将送料牙升到针板的最高位置。

2.将缝纫机放倒，并支到机头支柱上。

3.旋松抬牙叉形曲柄②上的紧固螺钉①。

4.转动抬牙叉形曲柄②进行调节：将抬牙叉形曲柄②向A方向转动，送料牙将变高；反之向B



注意:



1.为了防止缝纫机的意外启动，请关掉电源之后再进行操作。

1.Turn the pulley until the feed dog rises to the highest position.

2.Turn over the sewing machine head on th

方向转动，送料牙将变低(当送料牙升到针板的最高位置时，中厚料机型送料牙距针板的标准高度为0.8-1.0mm，厚料机型的标准高度为1.1-1.3mm)。

5.调节完成后拧紧抬牙叉形曲柄②上的紧固螺钉①。

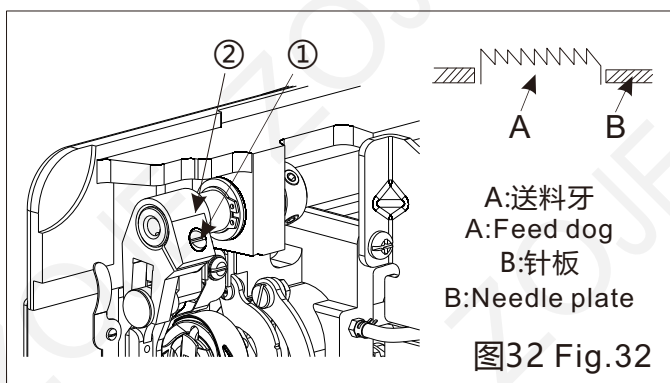

-e supporting bar.

3.Unscrewing the tightened screw ① in the feed lifting crank ②.

4.Rotating the feed lifting crank ② to make adjustment: the feed dog will be higher when the feed lifting crank ② is turn towards A direction; turn towards B direction the feed dog will be lower.(When the feed dog in the highest position, the standard height of the type of medium-heavy machine is 0.8~1.0mm and standard height of the heavy duty machine is 1.1~1.3mm) .

5.Remember to tighten the tightening screw ① in the feed lifting crank ② after adjusting.



Caution:

1.To prevent the unexpected startup of sewing machine, trim off the power supply before the operation is conducted.

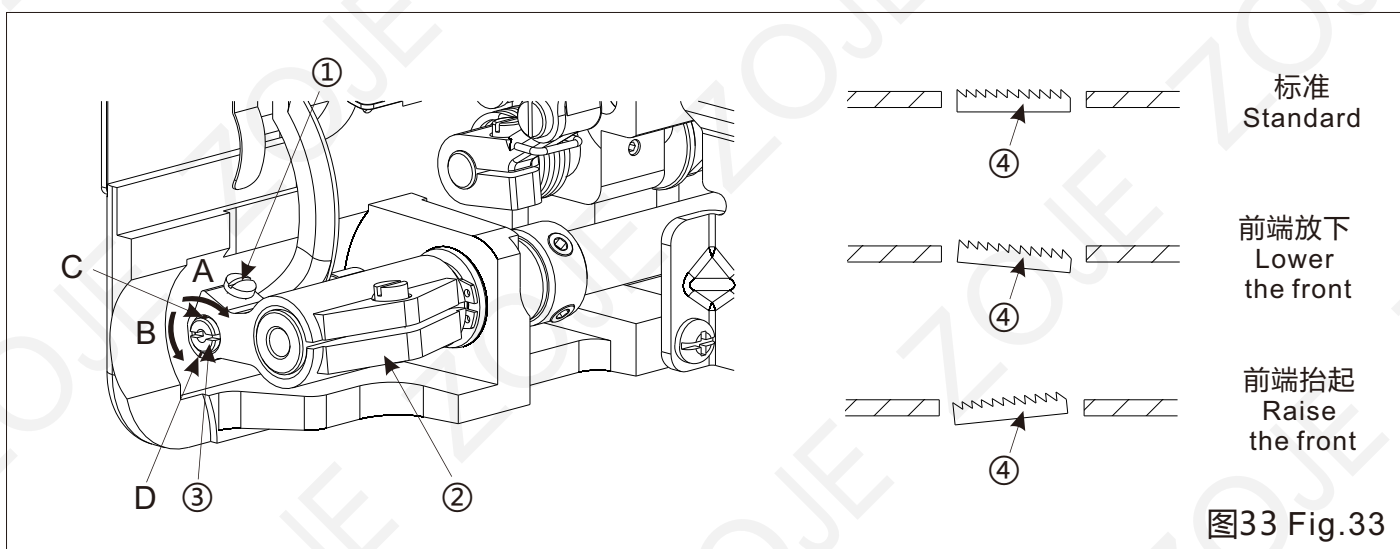

29 送料牙倾斜的调节 (图33) Adjust the lean of feed dog(Fig. 33)

- 1.转动手轮，将送料牙④升到针板的最高位置。
- 2.将缝纫机放倒，并支到机头支柱上。
- 3.旋松牙架座②上的紧固螺钉①。
- 4.用螺丝刀转动偏心销③进行调节：将偏心销③向A方向转动，送料牙前端放下；向B方向转动，送料牙前端抬起(当送料牙升到针板的最高位置时，送料牙标准倾斜为偏心销③上的刻点C与牙架座②上的刻横D对齐，送料牙与针板平

1.Turn the pulley until the feed dog ④ rises to the highest position.

2.Turn over the sewing machine head on the supporting bar.

3.Unscrewing the tightening screw ① in the teeth pedestal ②.

4.Adjust the eccentric pin ③ by screw driver:Fall front site of tooth feed when moving the eccentric pin ③ towards A, and raising it when move towards B.(When raising the tooth feed to the highest position, The standard lean position of feed dog is that mark C on eccentric pin ③ should be at the same level D with mark

行)。

5.调节完成后拧紧牙架座②上的紧固螺钉①。



注意:



1.为了防止缝纫机的意外启动,请关掉电源之后再进行操作。

2.为了防止起皱,可降低送料牙前端。

3.为了防止在重叠缝纫时布料不一致(缝线不合),可提高送料牙前端。

4.调节送料牙的倾斜度后,送料牙的高度也会发生改变,因此请重新调节送料牙的高度。

on the teeth pedestal ② and the feed dog should be parallel with needle plate.)

5.Remember to tighten the tightening screw ① in the teeth pedestal ② after adjusting.



Caution:



1.To prevent the unexpected startup of sewing machine, trim off the power supply before the operation is conducted.

2.In order to prevent puckering,lower the front of the feed dog.

3.In order to prevent the material from slipping,raise the front of the feed dog.

4.The height of the feed dog will change after the angle has been adjusted,so it will be necessary to re-adjust the height of the feed dog.

30 定刀和动刀的更换 (图34、图35、图36) Replacing the fixed knife and movable knife(Fig. 34, Fig. 35, Fig. 36)

1.定刀的拆卸方法

1) 将缝纫机放倒,并支到机头支柱上。

2) 松掉螺钉①,拆下旋梭定位钩②。

3) 松掉螺钉③,取出定刀④。



注意:



1.为了防止缝纫机的意外启动,请关掉电源之后再进行操作。

2.安装定刀顺序请按拆卸定刀顺序的相反步骤进行。



图34 Fig.34

1.Removing the stationary trimmer

1) Lay down the sewing machine head.

2) crew off screw ①, and remove positionin-g hook ② of rotating hook.

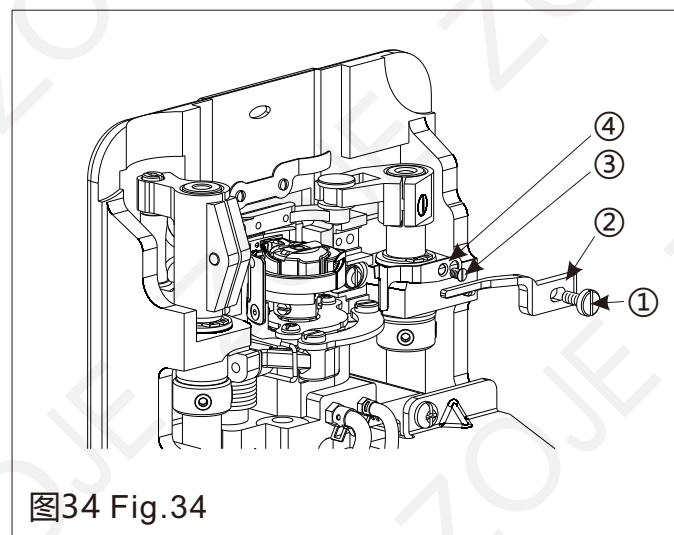
3) Screw off screw ③, and take out stationa-ry trimmer ④.

2.Grinding the stationary trimmer

If the cutting performance deteriorates,Sh- arpen the fixed knife ④ on a whetstone as Sh- own in the illustration ⑤.

3.Removing the movable trimmer

1)Remove the needle.

2)Uplift the presser foot using foot lifting le- ver.

3)Screw off screw ⑥ (2 pieces) , and take o- ut Clearance hole plate ASM.⑦.

4)Turn the handwheel to allow the needle b- ar to reach its highest position.

5)Lay down the sewing machine head.

6)Push thread-trimming driving crank lever ⑧ in direction of arrow till the position of scre



Caution:



1.To prevent the unexpected startup of sewing machine, trim off the pow- er supply before the operation is co- nducted.

2.Carry out the above steps in rever- se to install the fixed knife.

2.定刀刀刃的研磨方法

如果定刀的刃部受损或磨损，请将定刀④如图35所示在油磨石⑤上研磨定刀。

3.动刀的拆卸方法

- 1) 取下机针。
- 2) 用抬压脚扳手将压脚抬起。
- 3) 松掉螺钉⑥(2颗)，然后取出排屑斗板组件⑦。
- 4) 转动缝纫机手轮，将针杆上升至最高位置。
- 5) 将缝纫机放倒，并支到机头支柱上。
- 6) 按箭头所示方向方向推动切线驱动曲柄⑧直至看到螺钉⑨的位置为止。
- 7) 松掉螺钉⑨(2颗)，然后取出动刀⑩。



注意:



- 1.为了防止缝纫机的意外启动，请关掉电源之后再进行操作。
- 2.安装动刀顺序请按拆卸动刀顺序的相反步骤进行。

-w ⑨ is exposed.

7)Screw off screw ⑨ (2 pieces), and take out movable trimmer ⑩.



Caution:

1. To prevent the unexpected startup of sewing machine, trim off the power supply before the operation is conducted.



2. Carry out the above steps in reverse to install the movable knife.



图35 Fig.35



图36 Fig.36

31 剪线装置的调节 (图37)

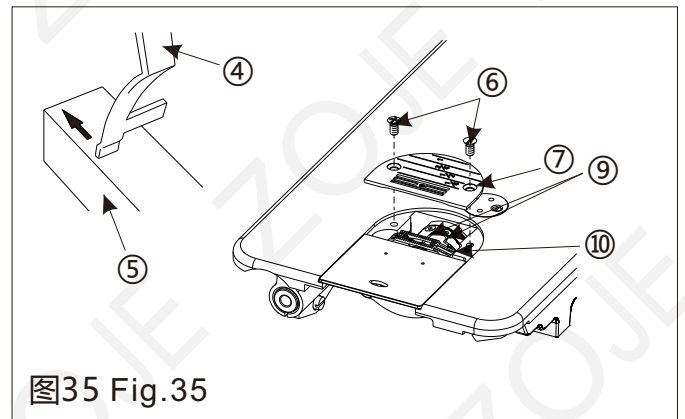
Adjusting the Thread-trimming Device(Fig. 37)

动刀、定刀位置的调节

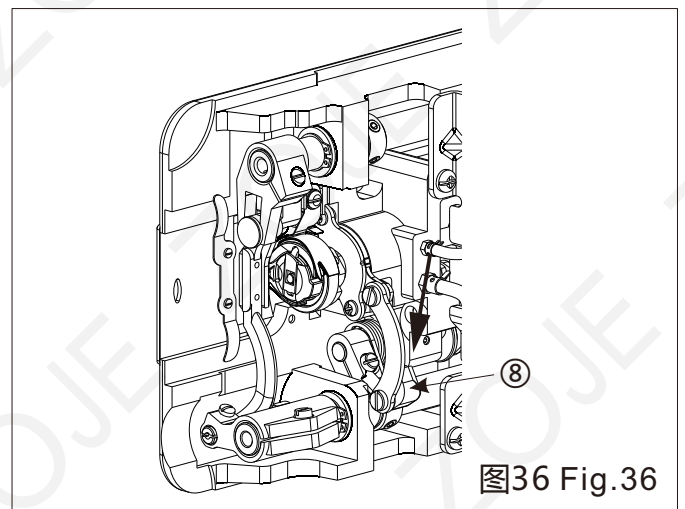
通过电控操作面板高级参数调试剪线功能，使步进电机驱动切线驱动曲柄①带动动刀②做剪线动作时，定刀③前端与动刀②刃口应当啮合0.2~0.5mm。如果没有啮合，通过调整电控操作面板参数使定刀③的前端与动刀②的刃部啮合。动刀②、定刀③位置调节后要能保证在手动剪线时能剪断203棉线。

Adjusting the positions of movable trimmer and stationary trimmer

By adjusting the thread cutting function through advanced parameters on the electronic control operation panel, the stepper motor drives the tangent drive crank ① to drive the moving knife ② for thread cutting action. When the front end of the fixed knife ③ engages with the cutting edge of the moving knife ② by 0.2 -0.5mm. If there is no engagement, adjust the parameters of the electronic control operation panel to engage the front end of the fixed knife



图37 Fig.37

③ with the edge of the moving knife ②. After adjusting the positions of the moving knife ② and the fixed knife ③, it should be possible to cut 203 cotton threads manually.



Caution:

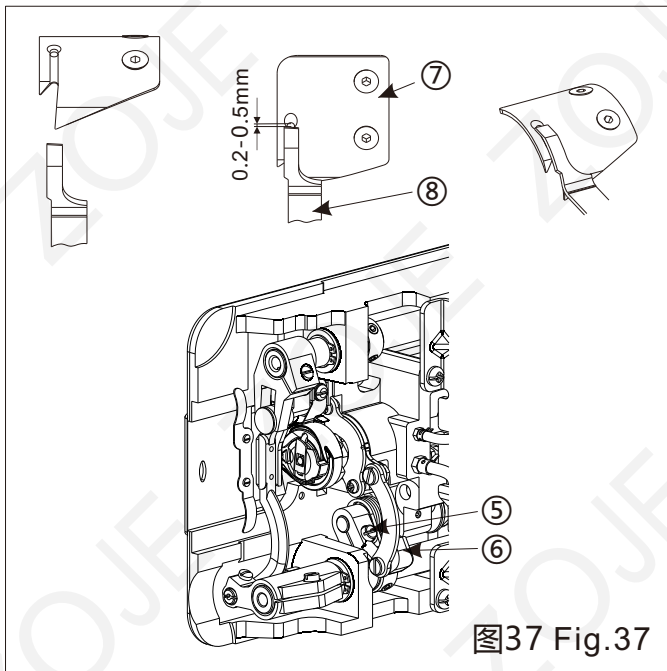

1. To prevent the unexpected startup of sewing machine, trim off the power supply before the operation is conducted.



注意:



1. 为了防止缝纫机的意外启动, 请关掉电源之后再进行操作。



图38 Fig.38



图39 Fig.39

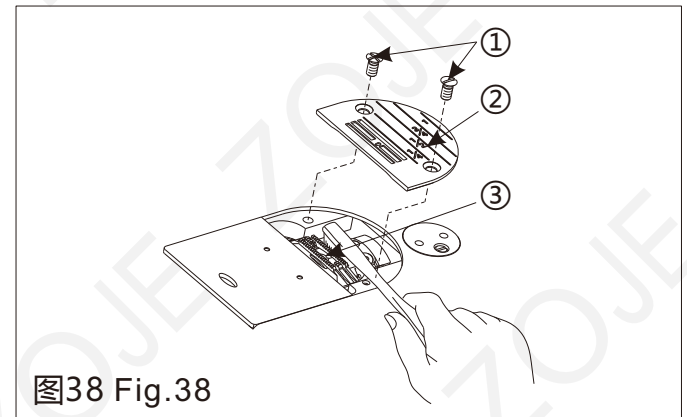

图40 Fig.40

32 保养 (图38、图39、图40) Maintenance (Fig. 38, Fig. 39, Fig. 40)

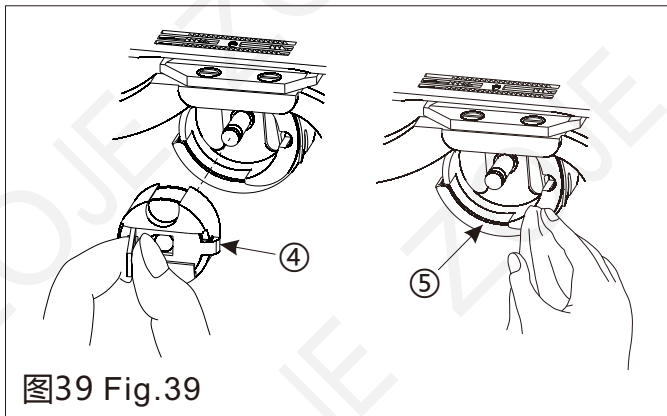
为了保持缝纫机的机能, 而能够长久的使用, 请每日进行以下的保养。

1. 确认齿轮箱油量

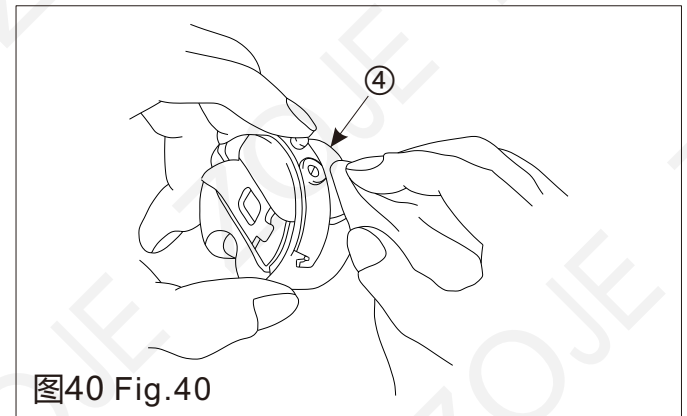
请确认油标的前端应该在油标指示窗的上刻线和下刻线之间。(详细内容请参考[5机器的加油])

2. 清扫

1) 抬起压脚。

The following cleaning operations should be carried out each day in order to maintain the performance of this machine and to ensure a long service life.

1. Ensuring the oil amount in gear case

Confirm that the top of oil amount indicating rod is between the upper engraved marker line and the lower engraved marker line of the oil amount indicating window. (For the details, refer to "5 Lubrication of machine")

2. Cleaning

- 2) 将两颗针板固定螺钉①拆下，然后再拆下针板②。
- 3) 用软毛刷清除送料牙③及剪线装置上粘附的灰尘。
- 4) 将针板②及两颗针板固定螺钉①装上。
- 5) 将缝纫机放倒，并支到机头支柱上。
- 6) 拆下梭芯套④。
- 7) 用软布擦去旋梭⑤上的灰尘，并确认旋梭⑤是否受损。再用软布把旋梭周围底盖内的灰尘也擦拭干净。
- 8) 将梭芯从梭芯套④拆下，用软布清洁梭芯套④。
- 9) 将梭芯装入梭芯套④，再将梭芯套④重新装入缝纫机。

- 1) Raise the presser foot.
- 2) Remove the two screws ①, and then remove the needle plate ②.
- 3) Remove dust adhered to feed dog ③ and thread trimmer unit with a soft brush or cloth.
- 4) Install the needle plate ② with the two screws ①.
- 5) Turn over the sewing machine down on the supporting bar of head.
- 6) Remove the bobbin case ④.
- 7) Wipe off any dust from the rotary hook ⑤ with a soft cloth, and check that there is no damage to the rotary hook ⑤. Wipe out with the cloth dust and hook oil drained in the under cover near the hook.
- 8) Remove the bobbin from the bobbin case ④ and clean the bobbin case ④ with a cloth.
- 9) Insert the bobbin into the bobbin case ④, and then place the bobbin case ④ back into the machine.

33 缝纫机的搬运及放置注意事项 (图41、图42)

Carrying and Placing of the Sewing Machine(Fig. 41, Fig. 42)

1. 缝纫机的搬运方法

请按图示那样,由两人来手持缝纫机机架主体进行搬运。

2. 放置缝纫机时的注意事项

放置缝纫机时, 请注意一定要水平的放置到平坦的地方。同时在放置缝纫机的地方, 请不要放螺丝刀等凸起物件。

1. Carrying of the machine

It needs to hold tight frame body of the sewing machine by two people as the picture shows.

2. Attention for placing

Must be put in the plain site. Clear the screwdriver or something embossment out of the placing site.

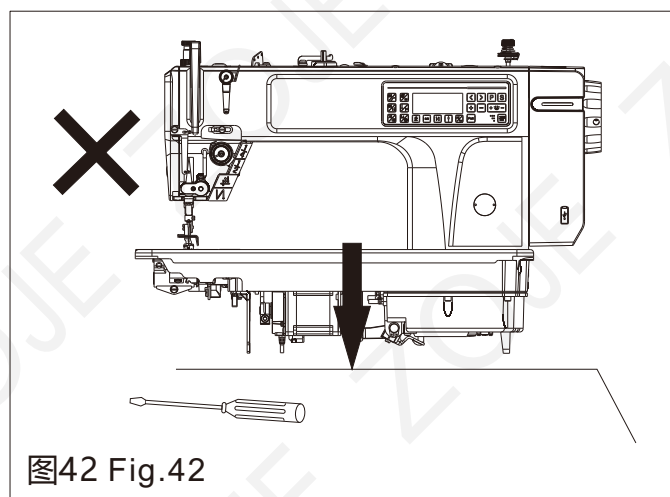
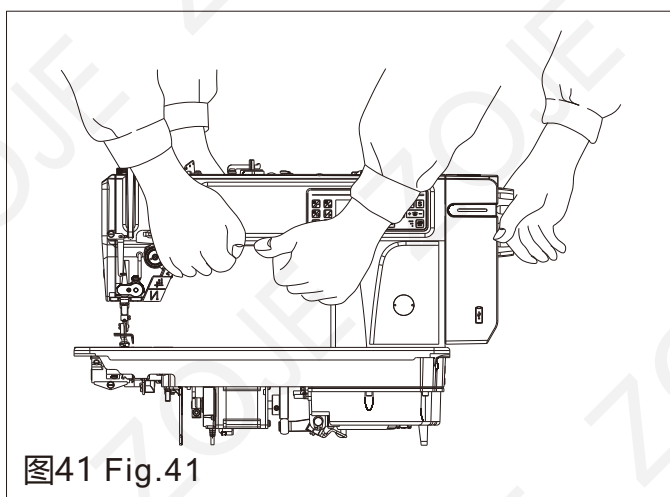

目 录

CONTENTS

零件样本 Parts Book

A	机壳分组件 Machine Frame & Miscellaneous Cover Components	30
B	上轴、挑线分组件 Main Shaft & Thread Take-up Cover Components	34
C	抬压脚分组件 Hang Lifter & Tension Release Components	38
D	勾线分组件 Hook Of Driving Shaft Components	40
E	送料分组件 Feed Mechanism Components	42
F	剪线分组件 Thread trimmer Components	46
G	电控分组件 Drive-by-wire Components	48
H	润滑分组件 Lubrication Components	50
I	油盘、膝抬压脚分组件 Presser Foot Components Of Oil Plate Knee Lift	52
J	过线架分组件 Components Of Thread-running Stand	54
K	附件 Auxiliaries	56

A

机壳分组件

Machine Frame & Miscellaneous Cover Components

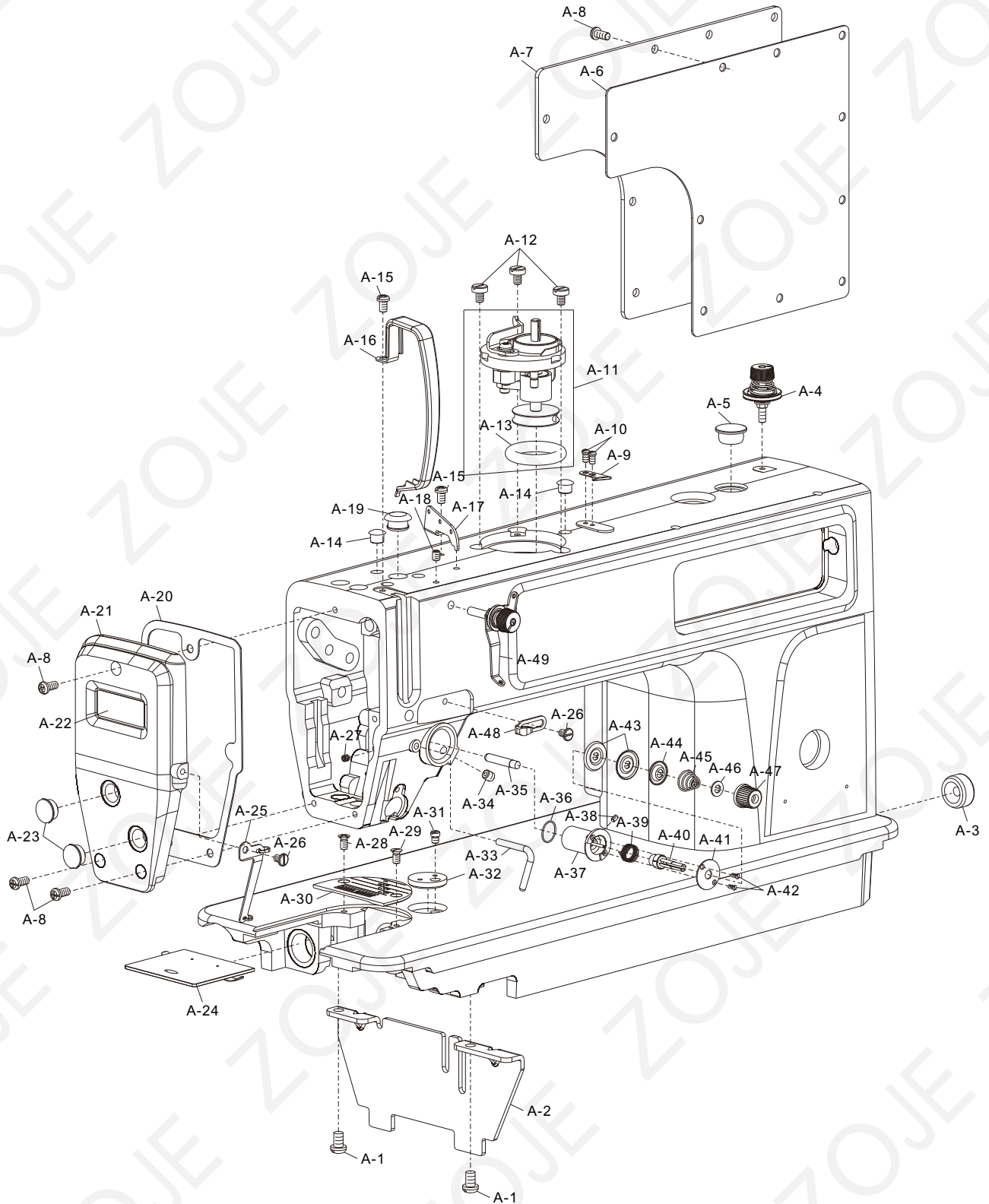

A

机壳分组件

Machine Frame & Miscellaneous Cover Components

序号 Ref. No.	件号 Part No.	名称	Name of part	数量 QTY	备注 Remark
A-1	10012142	SM15/64"×28螺钉	Screw SM15/64"×28	2	
A-2	10080301	前支撑板	Support plate	1	
A-3	10008941	橡胶塞	Rubber plug	1	
A-4	10062049	绕线夹线器组件	Bobbin thread tension ASM	1	
A-5	10078939	橡胶塞	Rubber plug	1	
A-6	10078954	后窗板垫	Side plate gasket	1	
A-7	20030728	后窗板	Side plate	1	
A-8	10008972	SM3/16"×28螺钉	Screw SM3/16"×28	10	
A-9	10011149	绕线切刀	Thread cutter	1	
A-10	10050423	SM9/64"×40螺钉	Screw SM9/64"×40	2	
A-11	10031086	绕线器	Bobbin wider ASM.	1	
A-12	10004380	SM3/16"×32螺钉	Screw SM3/16"×32	3	
A-13	10008773	橡胶轮	Rubber ring	1	
A-14	10008943	橡胶塞	Rubber ring	2	
A-15	10008934	SM3/16"×28螺钉	Screw SM3/16"×28	2	
A-16	20027103	挑线杆护罩	Thread take-up lever cover	1	
A-17	10052992	过线板	Thread tension guide	1	
A-18	10041529	SM3/16"×28螺钉	Screw SM3/16"×28	1	
A-19	10008942	橡胶塞	Rubber ring	1	
A-20	10077620	面板垫	Face plate gasket	1	
A-21	20031246	面板	Face plate	1	
A-22	*	面板装饰牌	Decorative board	1	
A-23	10008977	橡胶塞	Rubber ring	2	
A-24	10013706	推板部件	Push plate ASM.	1	
A-25	10069143	左线钩	Arm thread guide left	1	
A-26	10008973	SM11/64"×40螺钉	Screw SM11/64"×40	2	
A-27	10009074	M4螺钉	Screw M4	1	
A-28	10012463	SM11/64"×40螺钉	Screw SM11/64"×40	1	
A-29	10009005	SM11/64"×40螺钉	Screw SM11/64"×40	1	
A-30	10078267	针板组件	Needle plate	1	
A-30	10014459	针板组件	Needle plate	1	5
A-30	10068604	针板组件	Needle plate	1	S7
A-31	10004374	SM11/64"×40螺钉	Screw SM11/64"×40	1	
A-32	10068607	限位挡片	Ruler plate	1	
A-33	10038945	缓线钩	Presser bar thread guide	1	
A-34	10006264	SM15/64"×28螺钉	Screw SM15/64"×28	1	
A-35	10078914	松线辅钉	Tension release supporting pin	1	
A-36	10053484	17×1 O形圈	O-ring 17×1	1	
A-37	10080284	松线电磁铁	Electronmagnetic	1	
A-38	10002896	M4螺钉	Screw M4	1	
A-39	10053259	挑线弹簧	Spring	1	
A-40	10037581	夹线螺钉	Screw	1	
A-41	10051910	锁紧板	Lock plate	1	
A-42	10010399	SM3/32"×56螺钉	Screw SM3/32"×56	2	
A-43	10005489	过线板	Thread tension disk	2	
A-44	10004625	松线板	Thread tension disk presser	1	
A-45	10004176	弹簧	Spring	1	

“*” 具体内容需向客服咨询

“**” Specific content need to consult customer service

A

机壳分组件

Machine Frame & Miscellaneous Cover Components

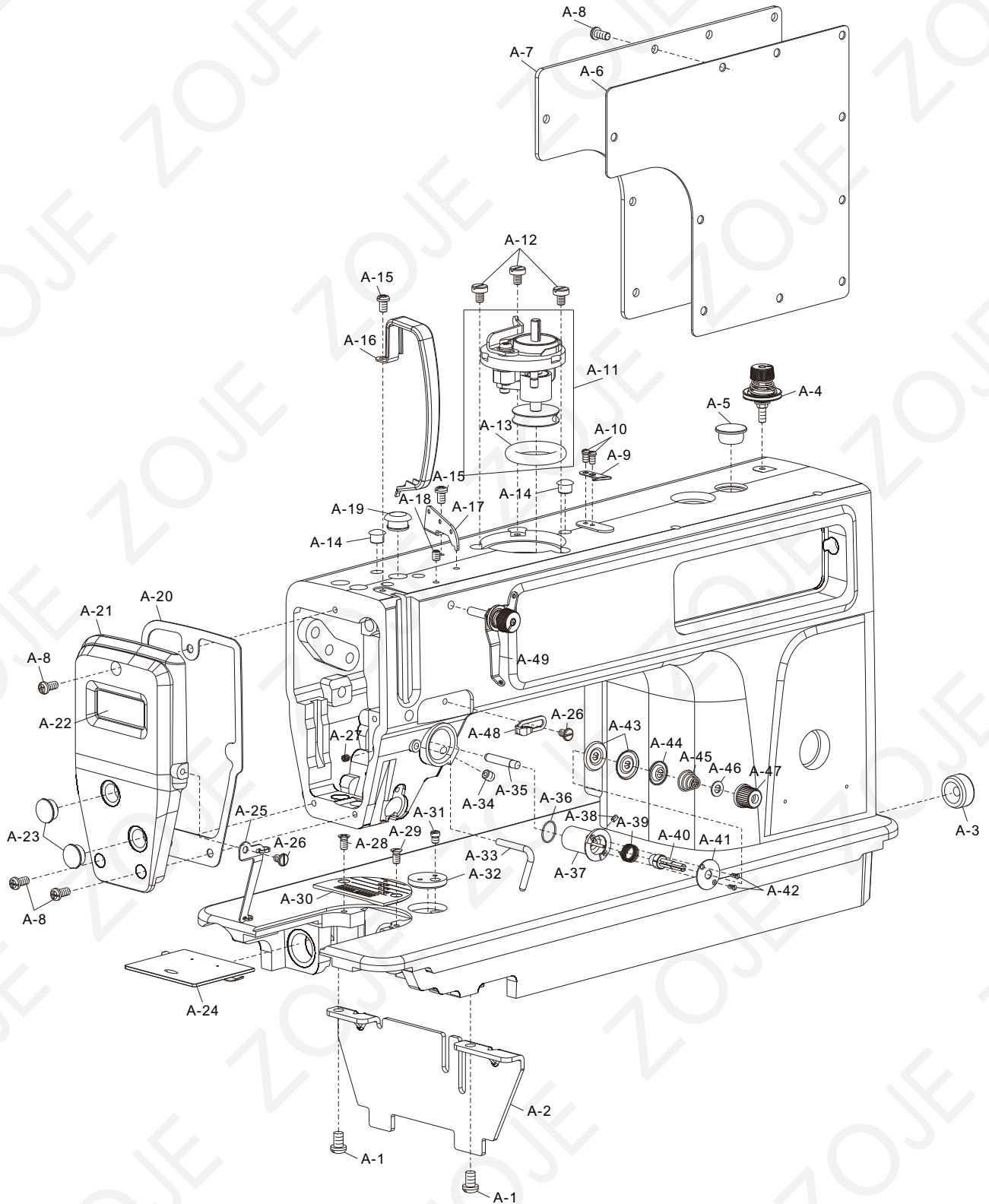

B

上轴、挑线分组件

Main Shaft & Thread Take-up Cover Components

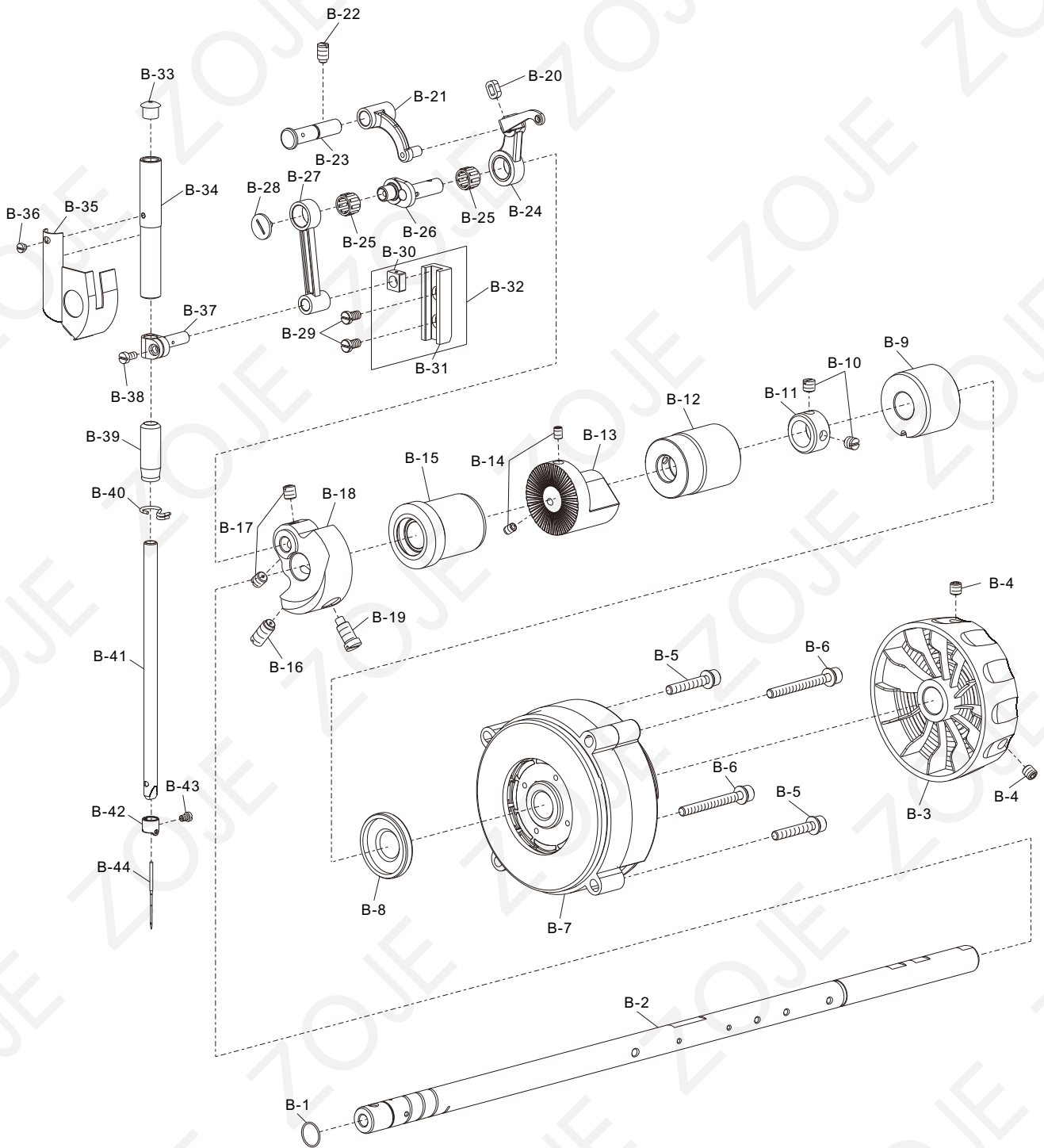

B

上轴、挑线分组件

Main Shaft & Thread Take-up Cover Components

序号 Ref. No.	件号 Part No.	名称	Name of part	数量 QTY	备注 Remark
B-1	10008886	O形圈	O-ring	1	
B-2	10074547	上轴	Main shaft	1	
B-3	20030172	上轮	Head wheel	1	
B-4	10011232	M6×6螺钉	Screw M6×6	2	
B-5	10077958	M5螺钉组件	Screw M5 ASM.	2	
B-6	10077959	M5螺钉组件	Screw M5 ASM.	2	
B-7	*	分体电机组件	Motor ASM.	1	
B-8	10058049	油封	Oil seal	1	
B-9	10066834	上轴后轴套	Shaft sleeve	1	
B-10	10005020	SM1/4"×40螺钉	Screw SM1/4"×40	2	
B-11	10010542	挡圈	Thrust collar	1	
B-12	10007239	上轴中轴套	Shaft sleeve	1	
B-13	10074614	绕线主动轮	Driving wheel	1	
B-14	10041529	SM3/16"×28螺钉	Screw SM11/64"×40	2	
B-15	10055615	上轴前轴套	Shaft sleeve	1	
B-16	10010082	SM9/32"×28螺钉	Screw SM9/32"×28	1	
B-17	10010065	SM1/4"×40螺钉	Screw SM1/4"×40	2	
B-18	10012203	针杆曲柄	Crank	1	
B-18	10012858	针杆曲柄	Crank	1	5
B-19	10010545	针杆曲柄定位螺钉	Screw	1	
B-20	10010539	挑线杆防油圈	Oil resistant cover	1	
B-21	10010535	挑线连杆	Connecting rod	1	
B-22	10010083	SM15/64"×28螺钉	Screw SM15/64"×28	1	
B-23	20019236	挑线连杆销组件	Pin ASM.	1	
B-24	10038474	挑线杆	Thread take-up lever	1	
B-24	10004158	挑线杆	Thread take-up lever	1	S7
B-25	10014107	K8×12×7.8滚针轴承	Needle bearing K8×12×7.8	2	
B-26	10004144	挑线曲柄部件	Crank ASM.	1	
B-26	10005937	挑线曲柄部件	Crank ASM.	1	5
B-27	10062407	针杆连杆	Connecting rod	1	
B-28	10010537	挑线曲柄左旋螺钉	Screw	1	
B-29	10043360	滑块导轨螺钉	Screw	2	
B-30	10052734	针杆连接柱滑块	Sliding block	1	
B-31	10052733	滑块导轨	Slide guide	1	
B-32	10054365	滑块导轨组件	Slide guide ASM.	1	
B-33	10010587	橡胶塞	Rubber plug	1	
B-34	10011063	针杆上轴套	Shaft sleeve	1	
B-35	10062045	面部防油板部件	ARM oil shield ASM.	1	
B-36	10005558	SM1/8"×44螺钉	Screw SM1/8"×44	1	
B-37	10052735	针杆连接柱	Joint pin	1	
B-38	10030286	SM9/64"×40螺钉	Screw SM9/64"×40	1	
B-39	10014117	针杆下轴套	Shaft sleeve	1	
B-39	10005916	针杆下轴套	Shaft sleeve	1	5
B-40	10005943	针杆下套线钩	Thread guide	1	
B-41	10008825	针杆	Needle bar	1	
B-41	10041609	针杆	Needle bar	1	5
B-42	10010588	SM1/8"×44螺钉	Screw SM1/8"×44	1	

“*” 具体内容需向客服咨询

“**” Specific content need to consult customer service

B

上轴、挑线分组件

Main Shaft & Thread Take-up Cover Components

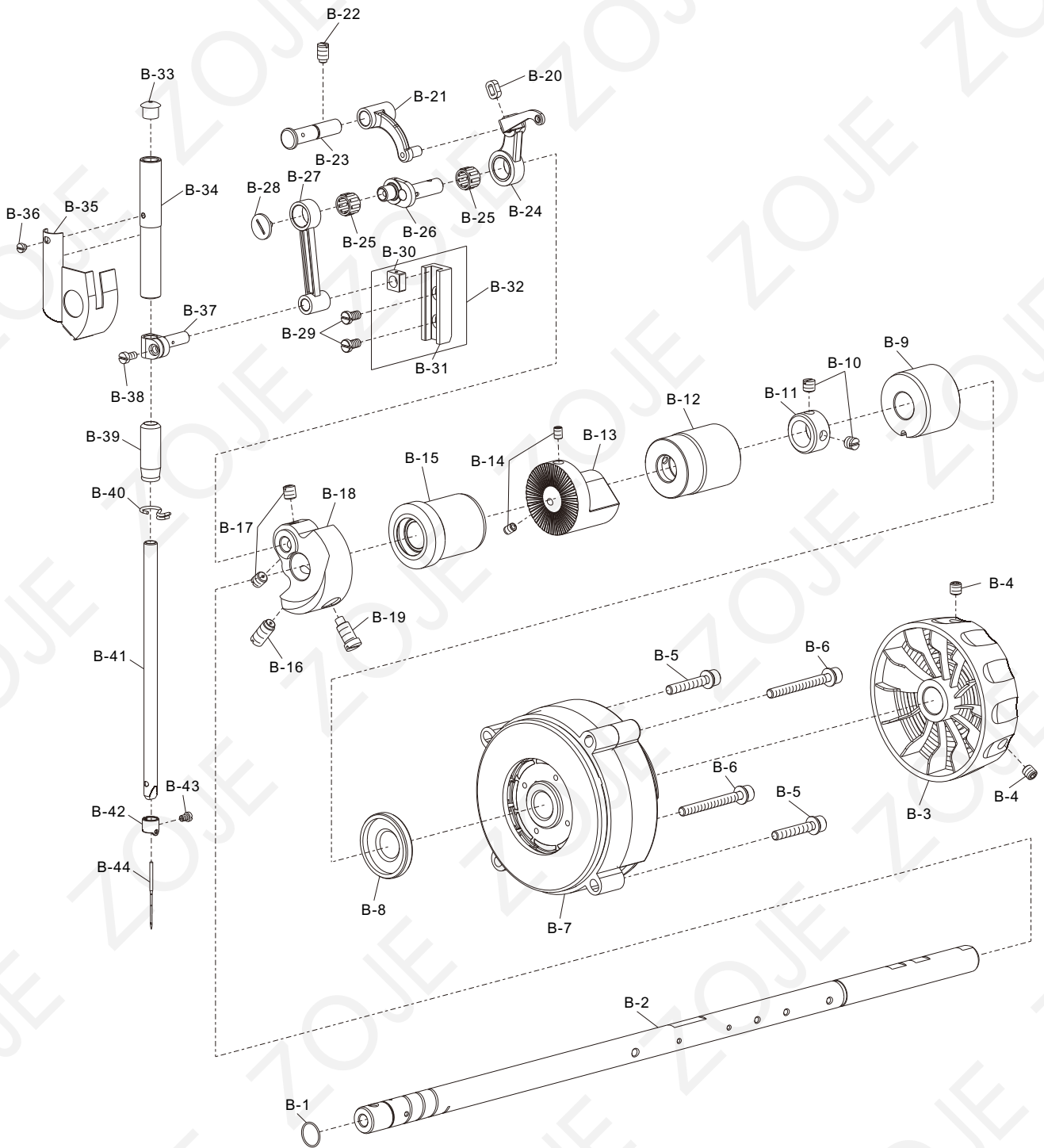

C

抬压脚分组件

Hang Lifter & Tension Release Components

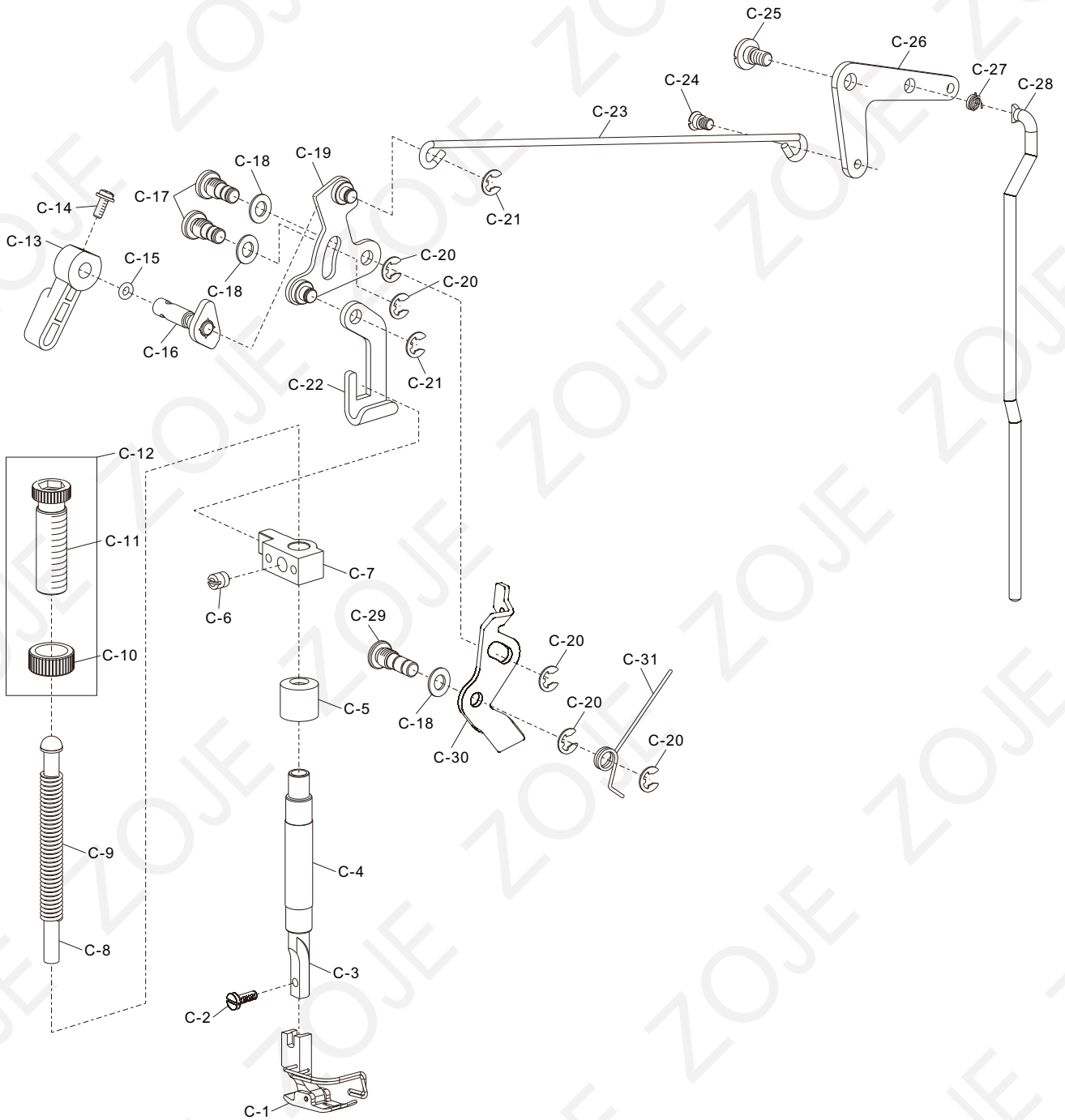

D

勾线分组件 Hook Of Driving Shaft Components

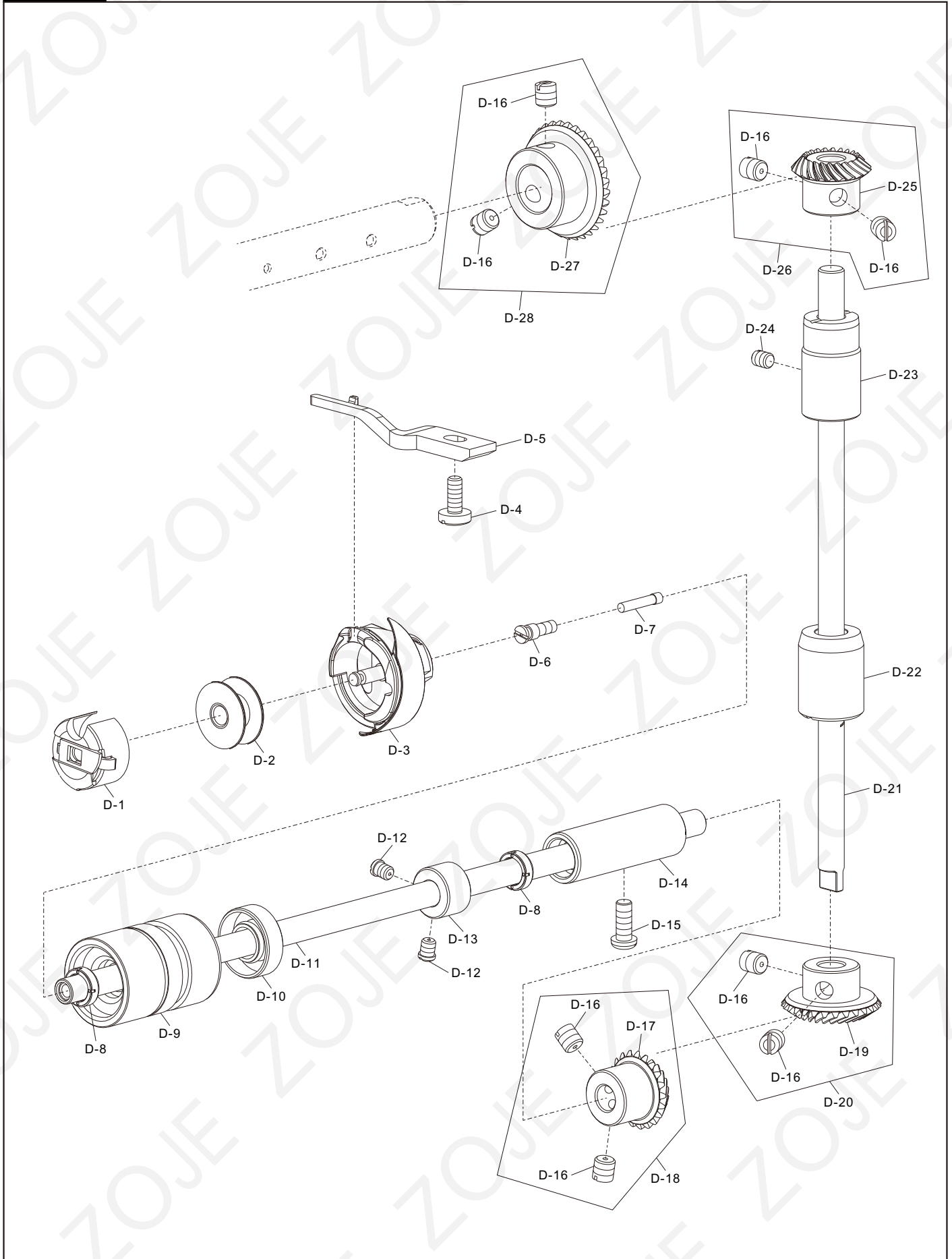

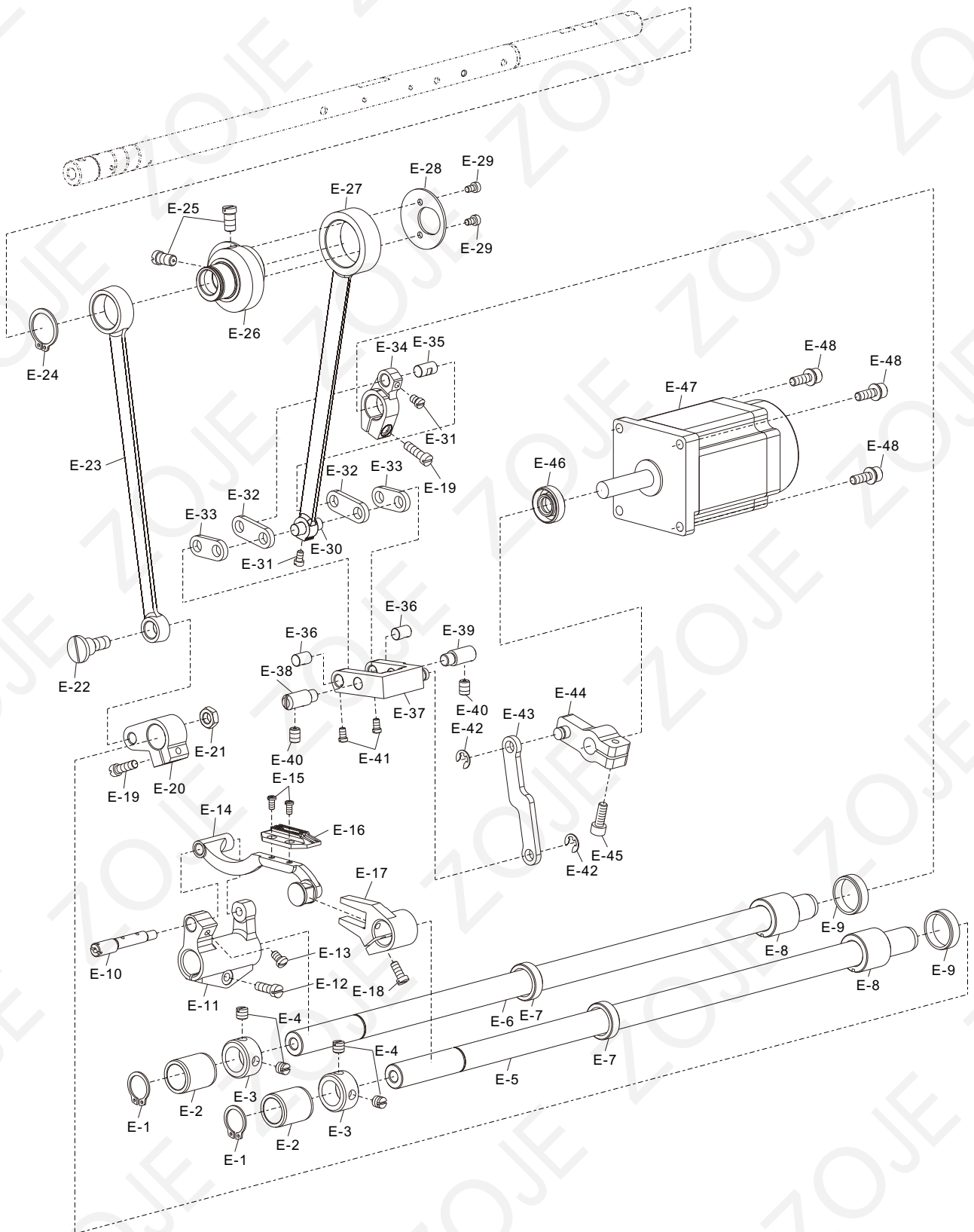

E

送料分组件

Feed Mechanism Components

序号 Ref. No.	件号 Part No.	名称	Name of part	数量 QTY	备注 Remark
E-1	10010090	13.8×1挡圈	Closing ring 13.8×1	2	
E-2	10058169	拾牙送料轴轴套	Shaft sleeve	2	
E-3	10010542	挡圈	Thrust collar	2	
E-4	10038073	SM1/4"×40螺钉	Screw SM1/4"×40	4	
E-5	10080295	拾牙轴	Feed driving shaft	1	
E-6	10080296	送料轴	Feed rocker shaft	1	
E-7	10012536	油封	Oil seal	2	
E-8	10052944	拾牙送料轴后轴套	Shaft sleeve	2	
E-9	10054363	橡胶塞	Rubber plug	2	
E-10	10004440	牙架座偏心销	Pin	1	
E-11	10004474	牙架座	Feed bar driving crank	1	
E-12	10004993	SM3/16"×28螺钉	Screw SM3/16"×28	1	
E-13	10010074	SM11/64"×40螺钉	Screw SM11/64"×40	1	
E-14	10070000	牙架部件	Feed bar ASM.	1	
E-14	10067264	牙架部件	Feed bar ASM.	1	S7/5
E-15	10010099	SM1/8"×44螺钉	Screw SM1/8"×44	2	
E-16	10052531	送料牙	Feed dog	1	
E-16	10026357	送料牙	Feed dog	1	S7
E-16	10007322	送料牙	Feed dog	1	5
E-17	10030200	拾牙叉形曲柄	Crank	1	
E-18	10004628	SM11/64"×40螺钉	Screw SM11/64"×40	1	
E-19	10010095	SM3/16"×28螺钉	Screw SM3/16"×28	2	
E-20	10010086	拾牙后曲柄	Crank	1	
E-21	10004475	SM9/32"×28螺母	Nut SM9/32"×28	1	
E-22	10010091	拾牙连杆轴位螺钉	Screw	1	
E-23	10010084	拾牙连杆	Connecting rod	1	
E-24	10010089	18.5×1.2挡圈	Closing ring 18.5×1.2	1	
E-25	10010092	SM1/4"×40螺钉	Screw SM1/4"×40	2	
E-26	10010115	送料偏心轮	Feed drive eccentric cam	1	
E-26	10005991	送料偏心轮	Feed drive eccentric cam	1	S7
E-27	10010072	送料连杆	Connecting rod	1	
E-27	10006004	送料连杆	Connecting rod	1	S7
E-28	10010098	送料偏心轮盖板	Thrust cover	1	
E-28	10005992	送料偏心轮盖板	Thrust cover	1	S7
E-29	10010643	SM9/64"×40螺钉	Screw SM9/64"×40	2	
E-30	10010069	送料连杆销	Pin	1	
E-31	10010071	SM9/64"×40螺钉	Screw SM9/64"×40	2	
E-32	10010068	送料长摆动板	Connecting plate	2	
E-33	10010075	送料短摆动板	Connecting plate	2	
E-34	10010076	送料曲柄	Crank	1	
E-35	10010096	送料曲柄销	Pin	1	
E-36	10010087	短摆动板连接销	Pin	2	
E-37	10005989	送料摆动板座部件	Feed adjusting ASM.	1	
E-38	10010102	送料摆动板座左销	Pin	1	
E-39	10058783	送料摆动板座右销	Pin	1	
E-40	10010678	SM15/64"×28螺钉	Screw SM15/64"×28	2	
E-41	10010197	SM9/64"×40螺钉	Screw SM9/64"×40	2	

“*” 具体内容需向客服咨询

“*” Specific content need to consult customer service

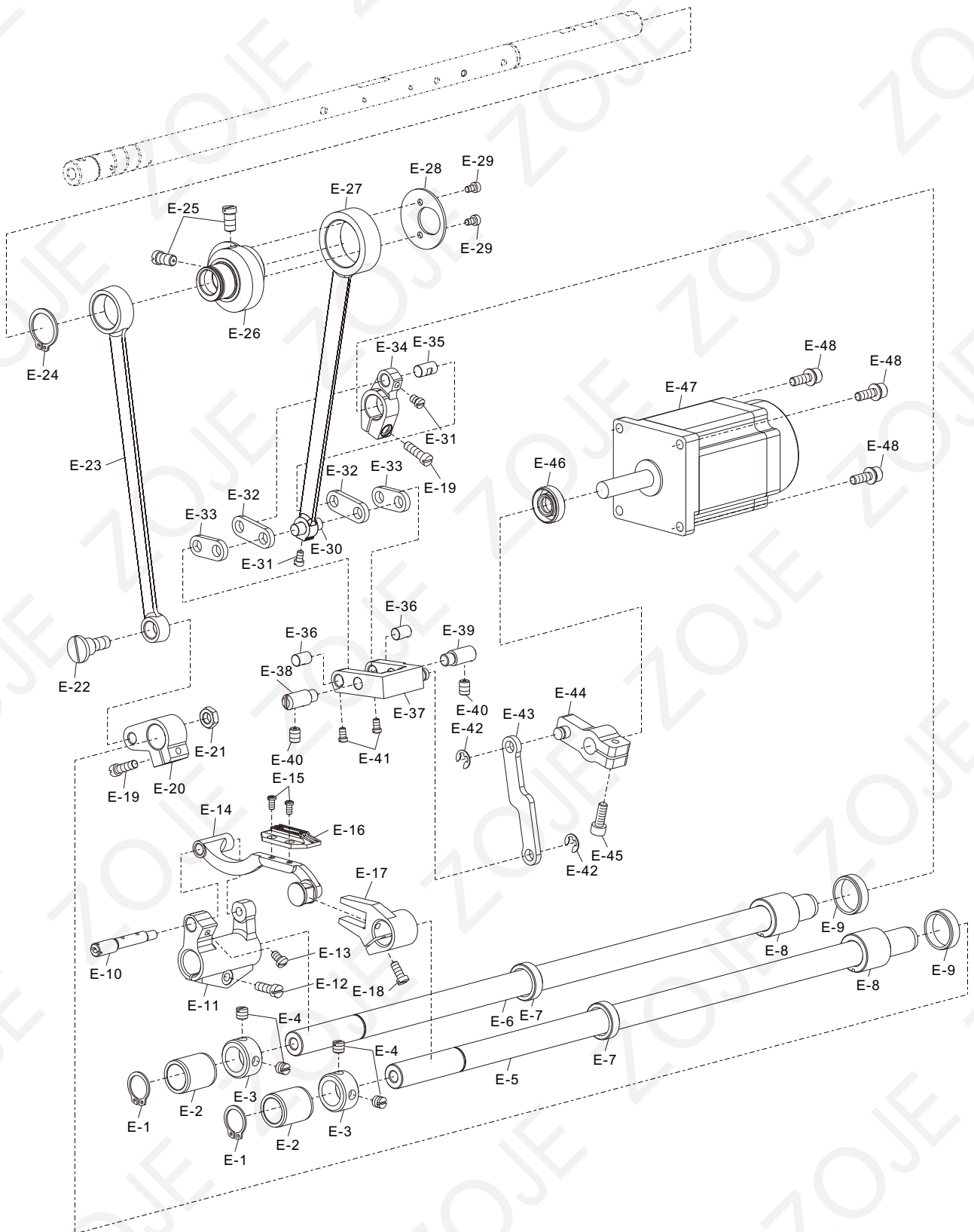

F

剪线分组件 Thread trimmer Components

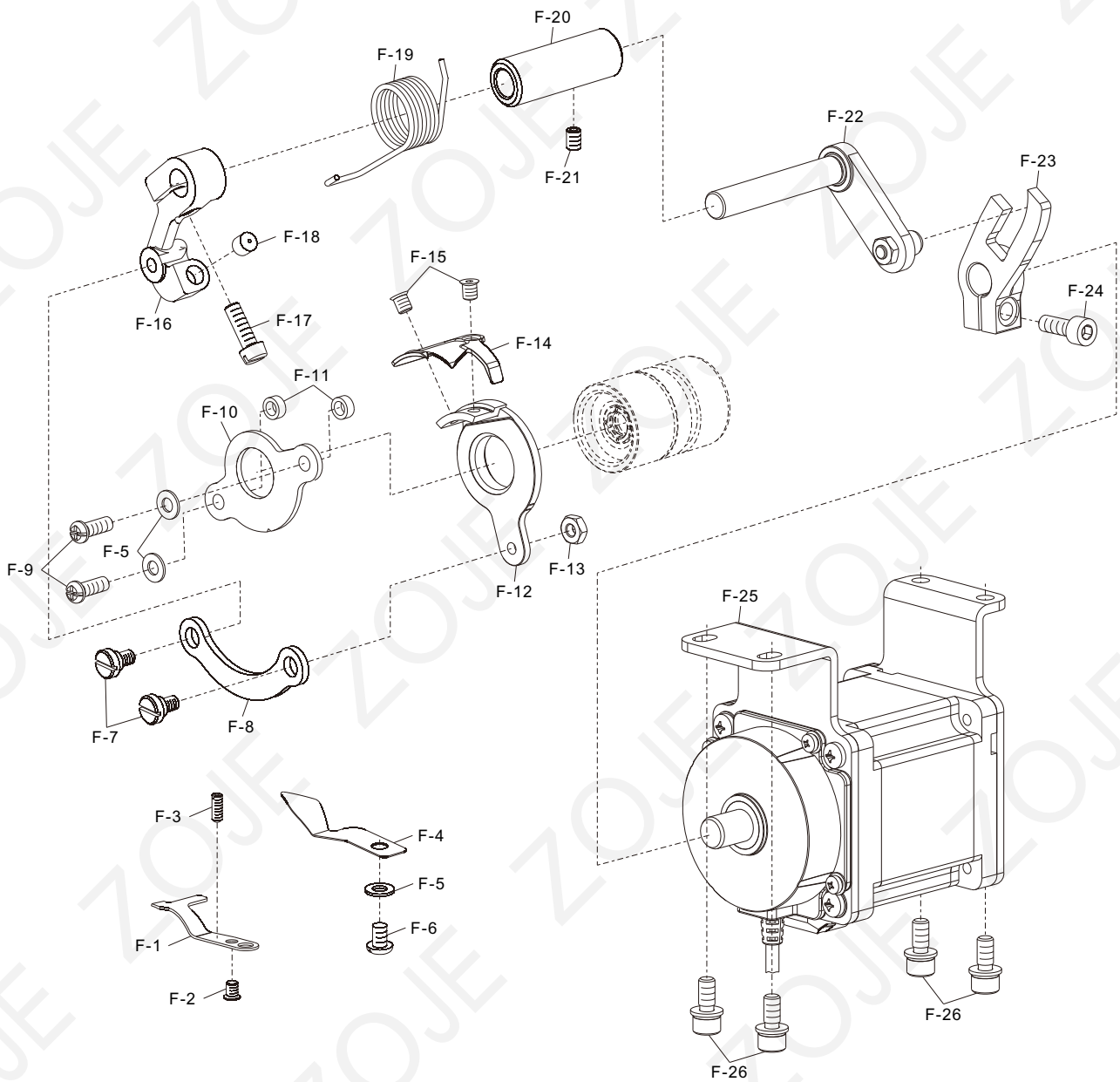

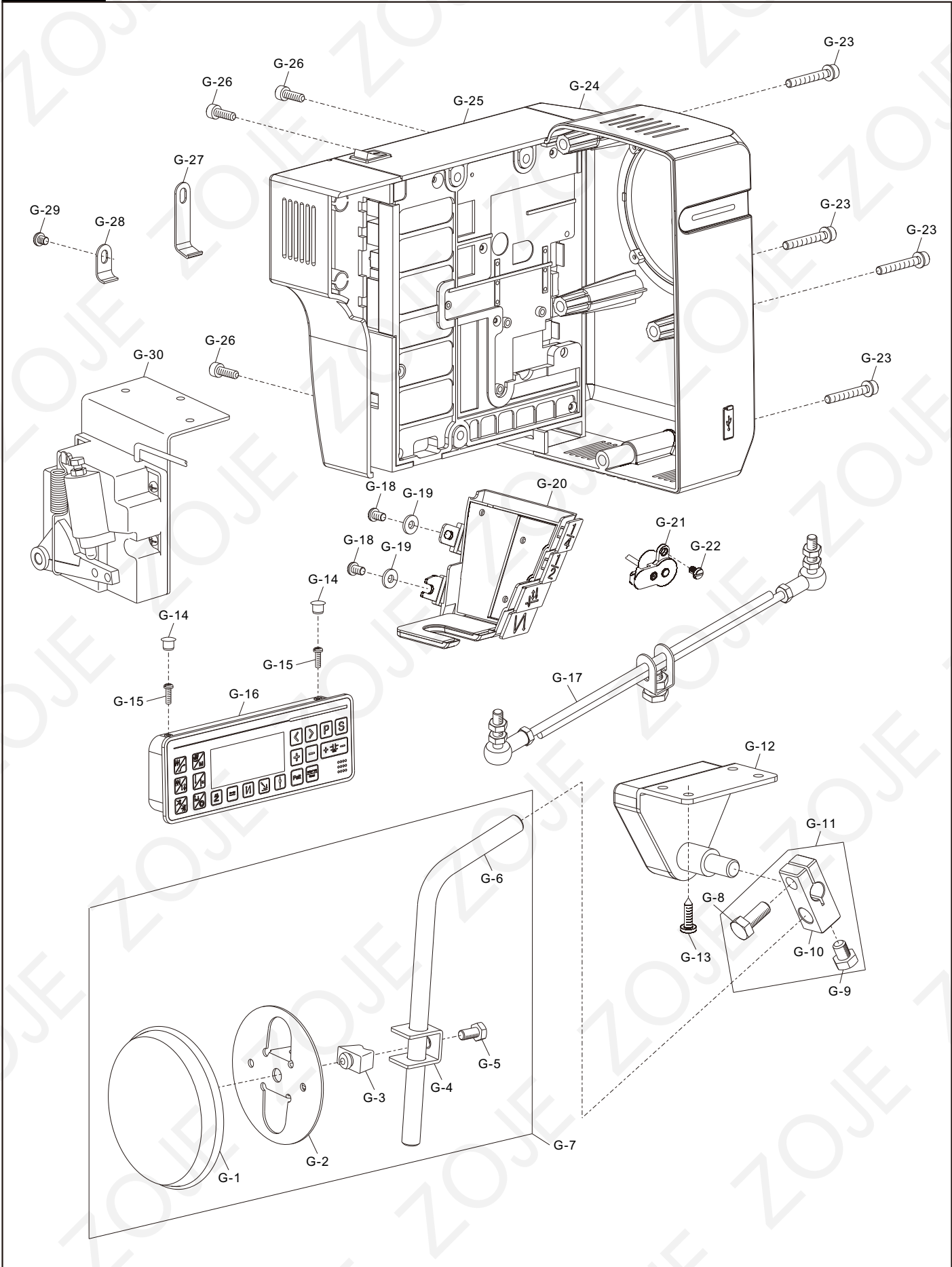



润滑分组件
Lubrication Components

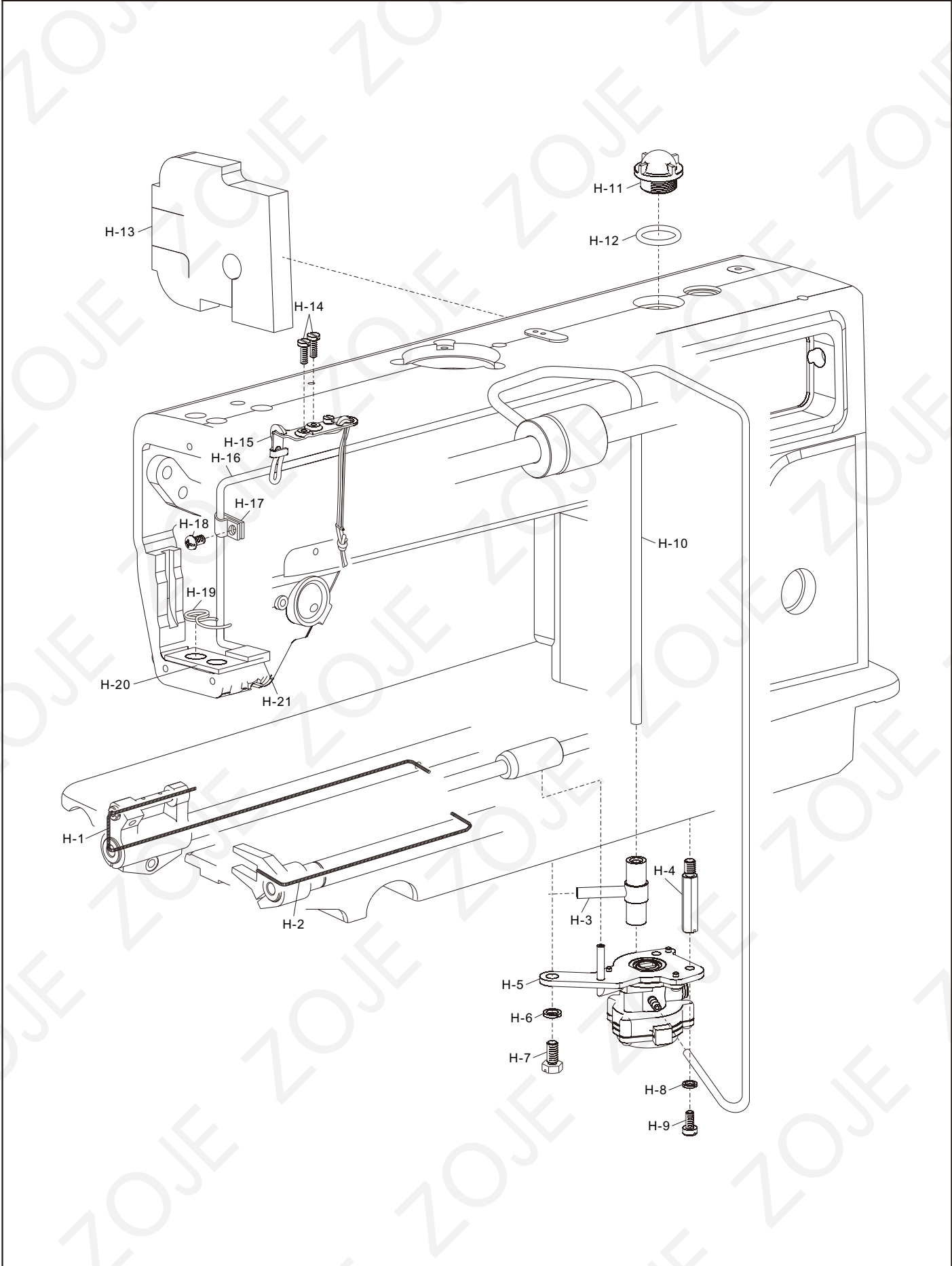

油盘、膝抬压脚分组件

Presser Foot Components Of Oil Plate Knee Lift

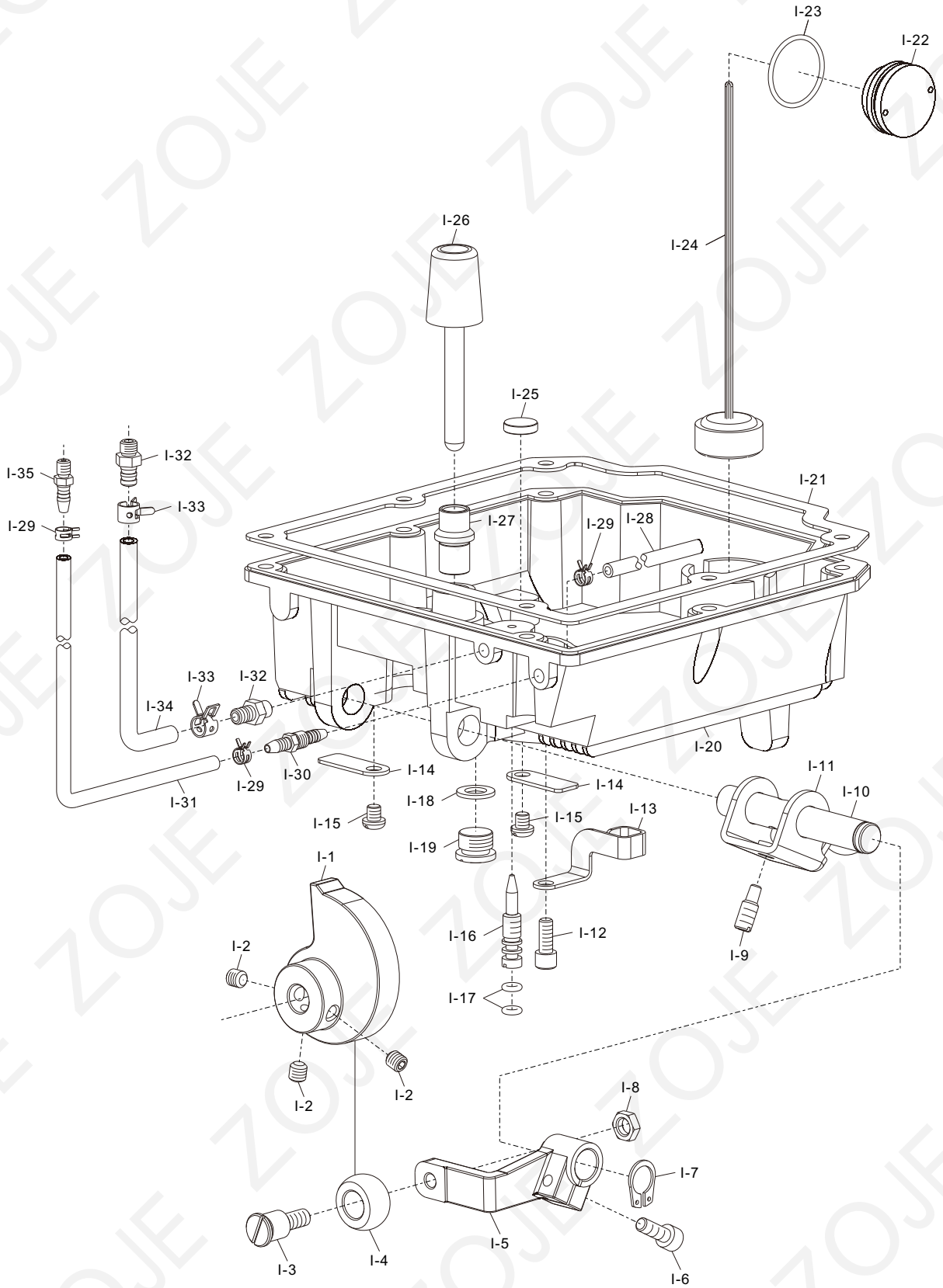

J

过线架分组件 Components Of Thread-running Stand

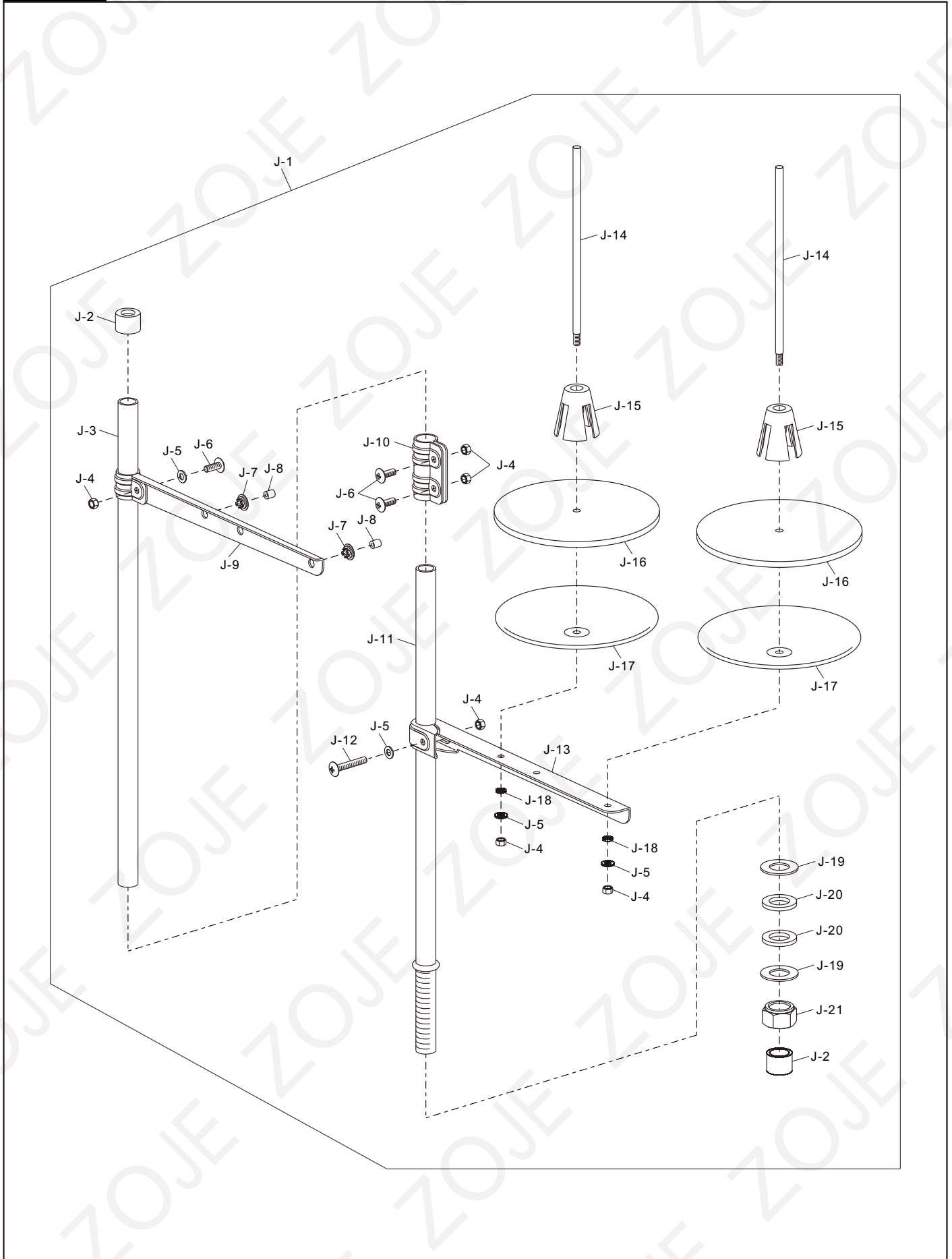

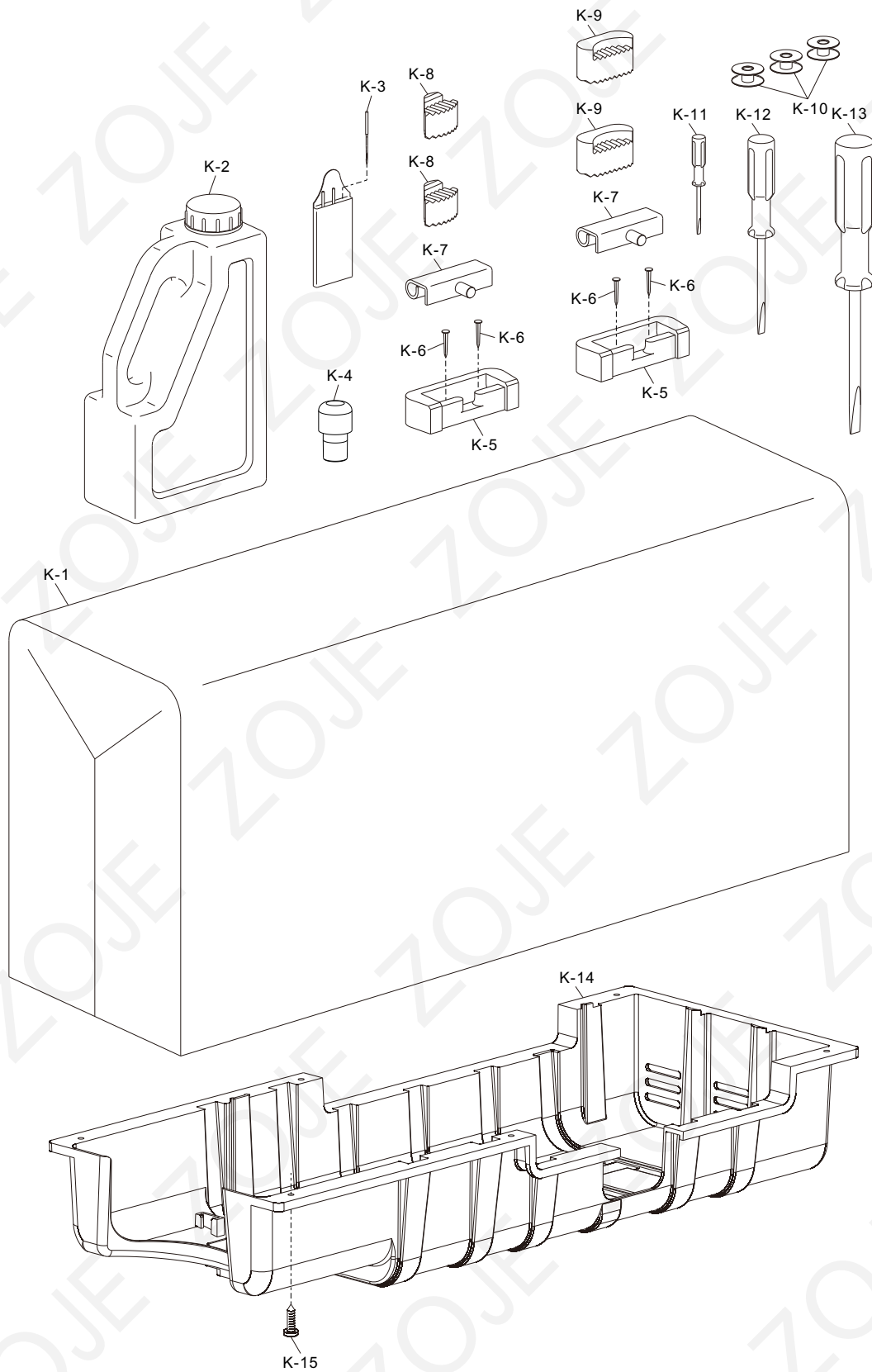

*请注意:由于产品改进,本手册内容可能会与实际购买的产品略有出入。



浙江中捷缝纫科技有限公司
ZOJE SEWING MACHINE CO.,LTD

地址:浙江省玉环市大麦屿街道兴港东路198号
ADD:DAMAIYU HING KONG ROAD NO. 198, YUHUAN,
ZHEJIANG, CHINA

国内营销中心: Domestic Marketing center
TEL:0576-87338345 87338215 FAX:0576-87338222

国际营销中心: Oversea Marketing center
TEL:+86-576-87377013 87378896 FAX: +86-576-87338266
Http://www.zoje.com E-mail:export@zoje.com